

# Cal. 2415/2405/2453

Basic analogue quartz watch movement

## 1. Basic Specification

Calibre	2415	2405	2453
Ligne	13-1/2'''		
Total height	4.35mm <small>Texte</small>		
Hands	3		
Function	Date	Day/Date	Enlarged Date
Battery life	3 Years		

### < Time Standard >

Type of quartz: Tuning fork type quartz crystal  
 Frequency : 32,768Hz  
 Accuracy : ±20 second / month worn under normal circumstances

### < Battery >

Type of battery: Silver oxide SR626SW or equivalent

### < Others >

Driving system: Two-pole stepping motor  
 Jewel : No jewels

### < Additional Mechanisms >

Quick Day/Date Change by turning crown  
 Powercell saving reset mechanism  
 Over-loading compensation device  
 Digital Frequency Control for tone adjustment

### < Balanceable weight of hand >

Minute hand Max. 0.4 μN.m  
 Second hand Max. 0.09 μN.m

## 2. Separated Parts

Calibre	2415	2405	2453
Setting stem	065-299		

## 3. Remarks

### < Setting stem >

Length of movement center to stem end : 20.0mm  
 Thread : Φ0.9mm x 12.38mm

### < Measurement of time >

The unit time of measurement must be set at "10s" or integer fold value of 10s owing to the DFC system. And the measurement must be carried out in state of a complete watch.

### < Marking on movement >

UNADJUSTED  
 (CAL NO.)  
 MIYOTA CO., JAPAN

< Typical clearance >

Mov't - Caseback : minimum 150  $\mu$  m or more

Hands - glass : 300 - 450 $\mu$ m\*

\* Depending and subject to the glass and case structure, and hand length.

< Bilingual day of week >

There are many kinds of bilingual day of week.

< How to set time and day/date >

Day/Date : Pull out the crown to the 1st click position.

Turn the crown clockwise for Weekday.

Turn the crown anticlockwise for Date.

Time : Pull out the crown to the 2nd click position and turn the crown until the time is set correctly.

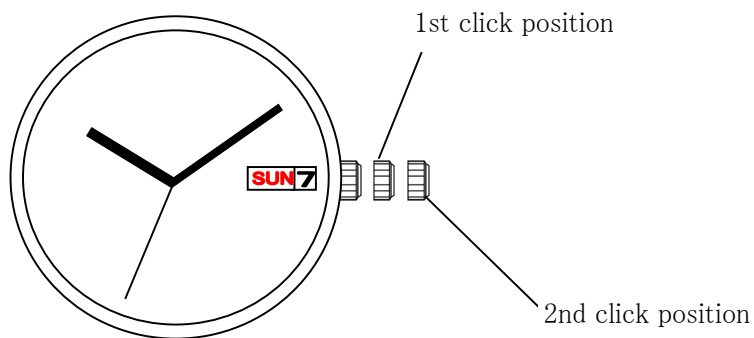

**These specifications might be changed without prior notice.**

2007/03/16 (10:25:46)

This drawing is provisional and subject to our reconfirmation and/or revision without notice.

DH11~DH12=28678±20

Coordinates

記号	X	Y
GM	0	0
DH11	-5600	-13200
DH12	5600	13200

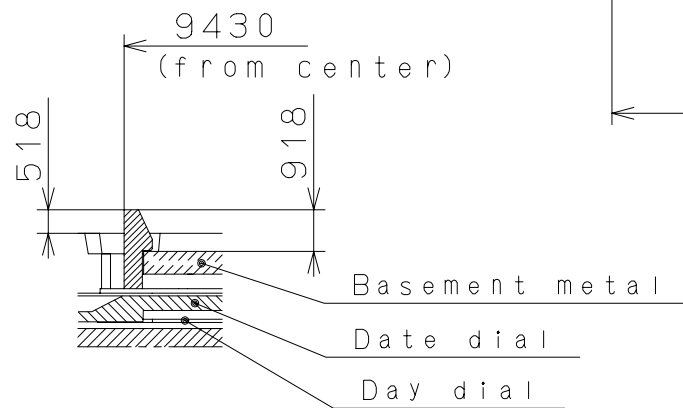
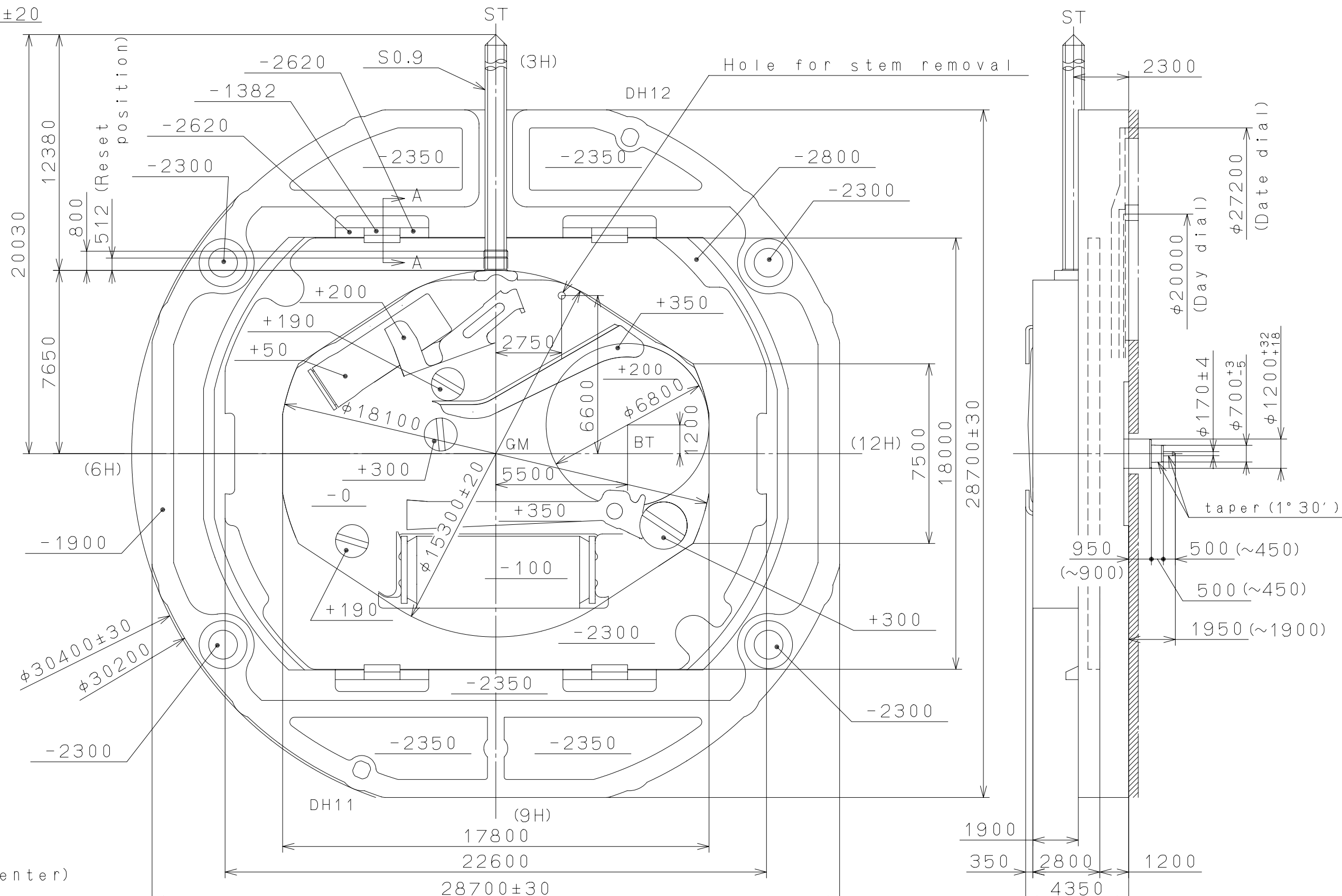

Section A-A (other hook)

△5			Quantity		Cal. NO.:
△4			Unit	1/1000 mm	2405
△3			Scale	6/1	Parts No.:
△2			Date		
△1			Drawn		
Mark	Date	Description	Checked	M. Fukuda	Name:
		Alterations	Approved		Frame for Case
Material			General Tolerances		Drawing No.: 2405C000
Heat Treatment			Dimensions		
Hardness			Angles		
Plating					

**MIYOTA**

CITIZEN WATCH CO., LTD. TOKYO, JAPAN

2007/03/16 (09:55:39)

This drawing is provisional and subject to our reconfirmation and/or revision without notice.

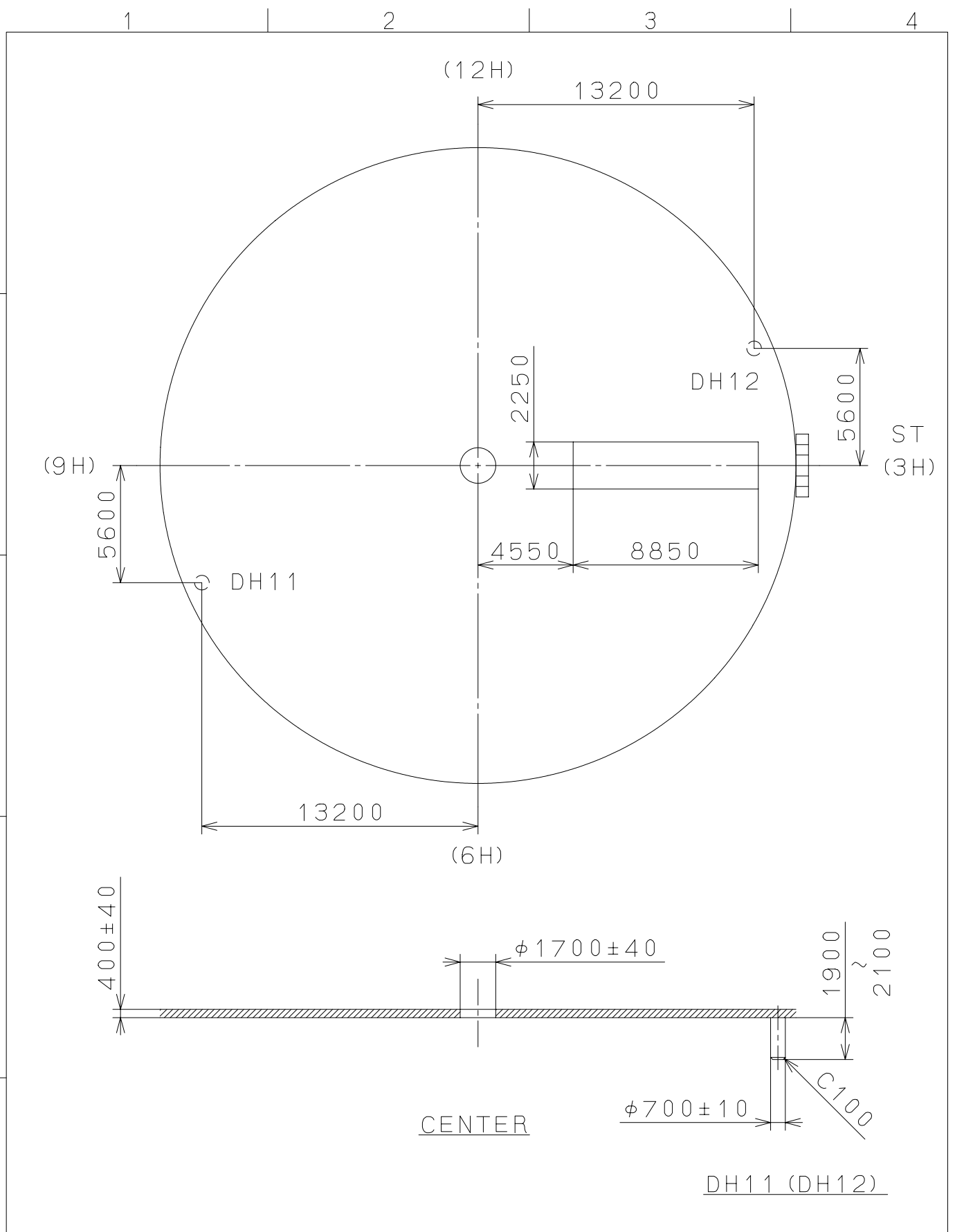

△			Quantity		Cal.NO.:
△			Unit	1 / 1000 mm	2405-00A
△			Scale	4 / 1	Parts No.:
△			Date		
△			Drawn		
Mark	Date	Description	Appr.	Checked	Name:
		Alterations	Approved	M. Fukuda	Indications for Dial
Material					Drawing No.: 2405D000
Heat Treatment			General Tolerances	<b>MIYOTA</b> CITIZEN WATCH CO., LTD. TOKYO, JAPAN	
Hardness			Dimensions		
Plating			Angles		

This drawing is provisional and subject to our reconfirmation and/or revision without notice.

\*\*\* T I P W (01) \*\*\* (2100 1121) 00-06-23

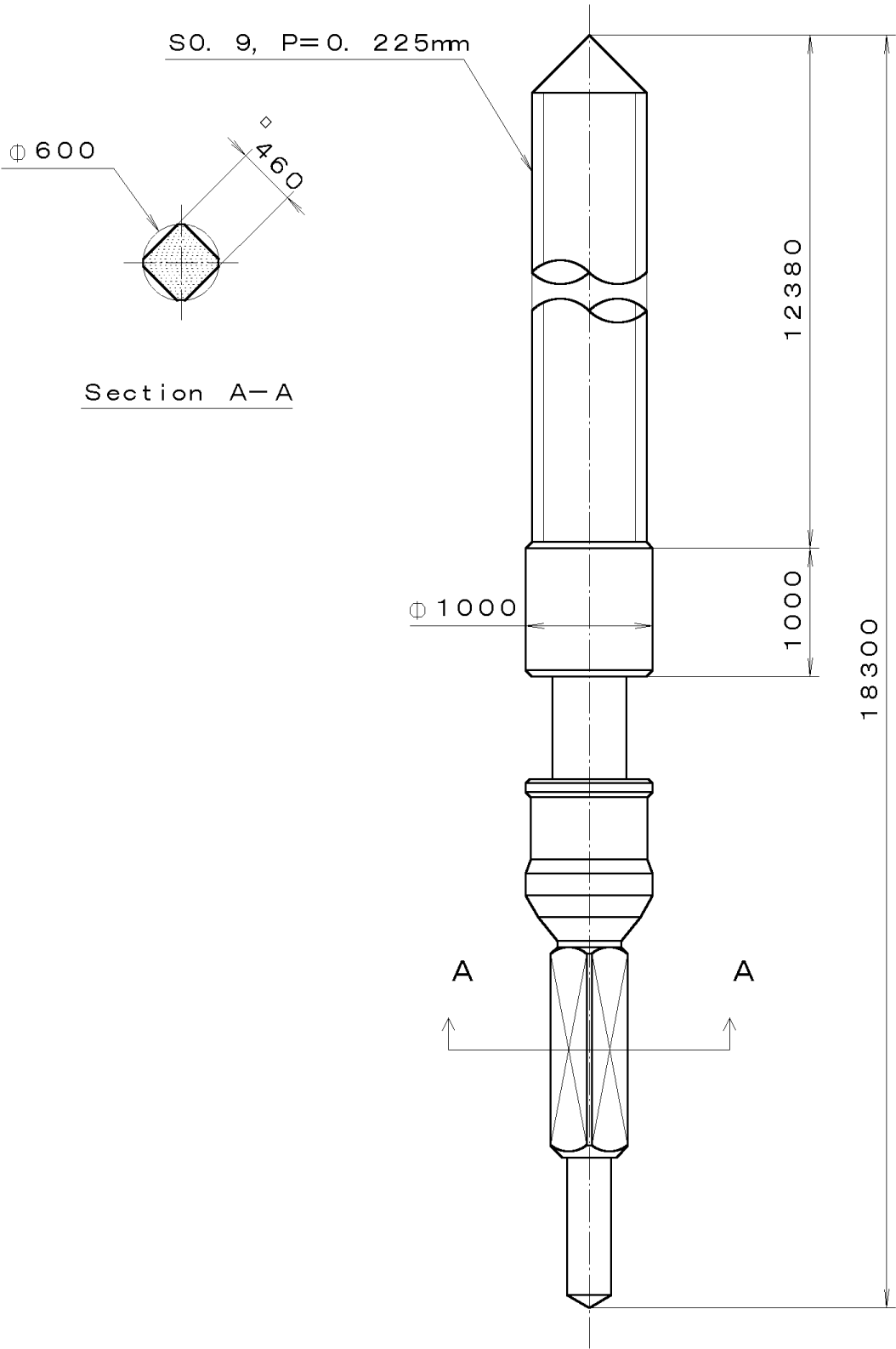

7			Quantity		Cal. No. :
6			Unit	1/1000 mm	Parts:
5			Scale	20:1	
4			Date		065-299
3			Drawn		
2			Checked	T. Hiruta	Name:
1			Approved		SETTING STEM
Material					Drawing No. : 2990S000
Heat Treatment			General Tolerances		<b>CITIZEN</b> WATCH CO.,LTD. TOKYO, JAPAN
Hardness			Dimensions		
Plating			Angles		