

PARTS CATALOGUE/TECHNICAL GUIDE

Cal. 5D22A

[SPECIFICATIONS]

Item		Cal. No.	5D22A
Movement			
Movement size	Outside diameter		Ø 30.0 mm
	Casing diameter		Ø 28.0 mm
	Height		6.25 mm
Time indication			3 hands (Hour, Minute and Second hands) Calendar (Date: date dial)
Driving system			Step motor 2 pieces
Additional functions			<ul style="list-style-type: none"> • Direct drive indicator <li style="padding-left: 20px;">Power reserve indicator <li style="padding-left: 20px;">Real-time power indicator • Energy depletion forewarning function • Overcharge prevention function • Electronic circuit reset function • Second hand stop function • Date correction function
Loss/gain			Monthly rate: less than 15 seconds (worn on the wrist at temperature range between 5 to 35 °C)
Regulation system			Nil
Measuring gate by quartz tester			Use 10-second gate.
Power supply	Power generator		Automatic generating system + Manual winding power generating system
	KINETIC E.S.U.		MT920 Manganese titanium lithium rechargeable battery
Operating voltage range			1.05V - 2.50V
Maximum Continuous operating time			Approximately 1 month after the watch is fully charged
Number of jewels			12 jewels

Remarks: Cal. 5D22A has basically the same design and construction as Cal. 5D44A but without Day retrograde hand. You may refer to the technical guide of Cal. 5D44A if you are already familiar with.

BEFORE STARTING REPAIR WORK ON CAL. 5D22A

SEIKO Kinetic Direct Drive Cal. 5D22 is an embodiment of the SEIKO's 'emotional technology'. The watch features new functions but the knowledge of repairing the existing KINETIC series will be helpful.

To repair the Cal. 5D22, therefore, you are requested to have the full knowledge of its functions and strictly observe the repairing and checking instructions provided in this guide so that the watch will be correctly repaired.

FEATURES

The Cal. 5D22 is a KINETIC watch equipped with two winding functions and two indicator functions.

● Two winding functions

As in all existing Kinetic calibers, the wearer automatically generates the electrical energy by her/his wrist movement. With Kinetic Direct Drive, however, the wearer can also generate energy by winding the crown.

● Two indicator functions

Kinetic Direct Drive shows not only the power held in reserve but also the level of power generation when the wearer hand-winds the crown. The wearer can see and feel, in real time, the direct transfer of power from his or her winding of the crown to the reserve.

1. DISPLAY AND HOW TO USE

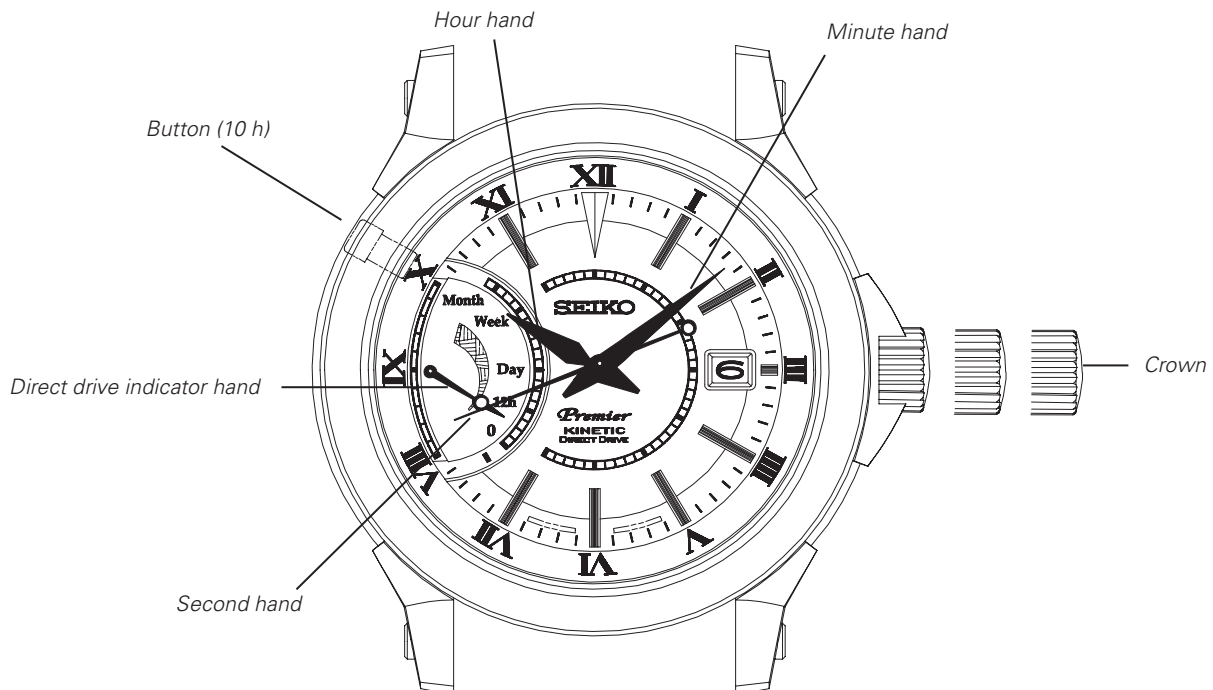

BEFORE STARTING REPAIR WORK ON CAL. 5D22A

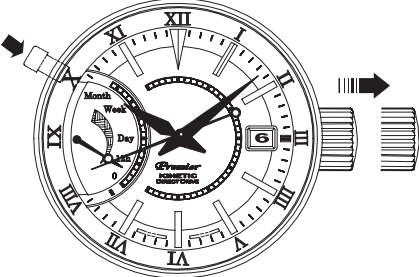
Crown position	Functions by crown operation	Functions by button operation
Normal	<ul style="list-style-type: none"> • Electric power generation by manual winding Clockwise turn: charging the watch by manual winding Counterclockwise turn: No function 	
First click	<ul style="list-style-type: none"> • Calendar setting Clockwise turn: no function Counterclockwise turn: date setting 	<p>Manual 0 position alignment of the direct drive indicator hand</p> <p>The watch automatically corrects the position of the direct drive indicator hand once every 24 hours. While correcting its position, the direct drive indicator hand automatically moves, but it is not a malfunction.</p> <p>How to manually correct the position of the direct drive indicator hand</p> <ul style="list-style-type: none"> • The position of the direct drive indicator hand can be also corrected by hand. <ol style="list-style-type: none"> 1. Pull out the crown to the first click. 2. Press the button located at the 10 o'clock position for 2 seconds or more. By doing this, the direct drive indicator hand returns to the standby position. 3. Press the button at the 10 o'clock position to set the position of the direct drive indicator hand pointing exactly to the 0 position.  <p><i>With each pressing of the button, the direct drive indicator hand moves up the scale by one increment. By pressing the button, adjustment can be made up to the second increment. At the third pressing of the button, the direct drive indicator hand returns to the standby position. Repeat the procedures until the direct drive indicator hand is correctly aligned to the 0 position.</i></p>

BEFORE STARTING REPAIR WORK ON CAL. 5D22A

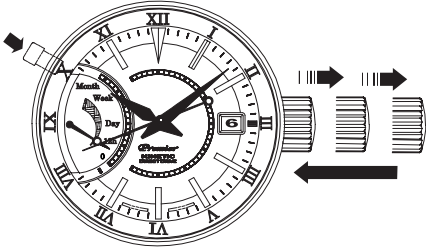
Crown position	Functions by crown operation	Functions by button operation
Second click	<ul style="list-style-type: none"> • Time setting 	<p>System reset (No power is generated.)</p> <p>If any improper function occurs, for example, the direct drive indicator hand stops moving while it is pointing anywhere other than the standby position, follow the instruction below to reset the built-in IC.</p> <ol style="list-style-type: none"> 1. Pull out the crown to the second click. 2. Press the button at the 10 o'clock position for 2 seconds or more. 3. Push the crown back into the normal position.  <p><i>After pushing the crown back into the normal position, charge the watch by manual-winding method and check that the hands start moving. At the same time the hands start moving, the direct drive indicator hand will return to point at the 0 position, and the watch will resume its normal operation.</i></p> <p><i>After the built-in IC is reset, the continuous operating time is cleared and the direct indicator hand points at the 0 position. If no power is generated subsequently, the watch will stop operating within three minutes. In order to avoid this, charge the watch at least until the direct drive indicator hand points at the first indication on the dial. It is also recommended that you correct the position of direct drive indicator hand manually as instructed on page 3.</i></p>

2. CHARACTERISTICS OF MANUAL WINDING FUNCTION OF KINETIC DIRECT DRIVE

1. As for mechanical watches, the amount of power generated increases in proportion to the number of times the mainspring is wound. As for the KINETIC DIRECT DRIVE watches, however, the amount of power generated by manual winding varies depending on the speed and length of strokes in which you wind the crown.

The more efficiently the power is generated, the more the direct drive indicator hand moves. It is even possible to reach the maximum scale value of power reserve with only one stroke.
2. The size of the crown will also affect the amount of power generated by manual winding.

Even if the crown is turned in exactly the same manner, the amount of power generated will vary depending on the size or the shape of the crown.

Generally, the smaller the crown is, the more efficiently the watch can generate the power.

BEFORE STARTING REPAIR WORK ON CAL. 5D22A

3. HOW THE DIRECT DRIVE INDICATOR HAND WORKS

1. Power reserve indicator function

- Except when the crown is being turned to charge the watch, the direct indicator hand functions as a power reserve indicator which shows how long the watch will keep operating within the range between the minimum 3 hours and the maximum 1 month.

For more details, refer to " How to read the power reserve indicator" below.

- If the direct drive indicator hand indicates the 0 position, the watch will stop operating within 3 hours. When the watch stops, the direct drive indicator hand moves to the standby position to show that the watch stops operating due to a power shortage.
- The direct drive indicator hand constantly displays the most up-to-date amount of stored power. If the amount of stored power is increased by the wearer's wrist movement or by the manual crown windings, the direct drive indicator hand displays the increased amount of power accordingly. On the other hand, if the watch is left unworn and the stored power is decreased as the watch consumed some power during the time it is left unworn, the direct drive indicator hand displays the decreased amount of stored power accordingly.
- The maximum amount of power reserve that the watch can store is the amount of power reserve to keep the watch operating for one month. When more power is generated after the watch already stores this maximum amount of power, the power generated is not further accumulated, and the direct drive indicator hand shows the power reserve of one month.

How to read the power reserve indicator

Scale marking	0	1	2	3	4	5	6	7	8	9	10
Indication on dial			0								D
Power reserve display			0	3h	6h	9h	12h	15h	18h	21h	1 day

Scale marking	11	12	13	14	15	16	17	18	19	20
Indication on dial						W			M	
Power reserve amount	2 days	3 days	4 days	5 days	6 days	1W	2W	3W	30days	*note 1

- The scale marking indicates the minimum continuous operating time.

Scale marking	Power reserve
3	3 hours (Not shorter than 3 hours and not longer than 6 hours)
13	4 days (Not shorter than 4 days and not longer than 5 days)
17	2 weeks (Not shorter than 2 weeks and not longer than 3 weeks)
20 *note 1	

*note 1 *Even though the continuous operating time reaches one month, the direct drive indicator hand remains moving to show that the power generating function is operating.*

BEFORE STARTING REPAIR WORK ON CAL. 5D22A

2. Real-time power indicator function

<Display and movement flow of the direct drive indicator hand while charging the watch>

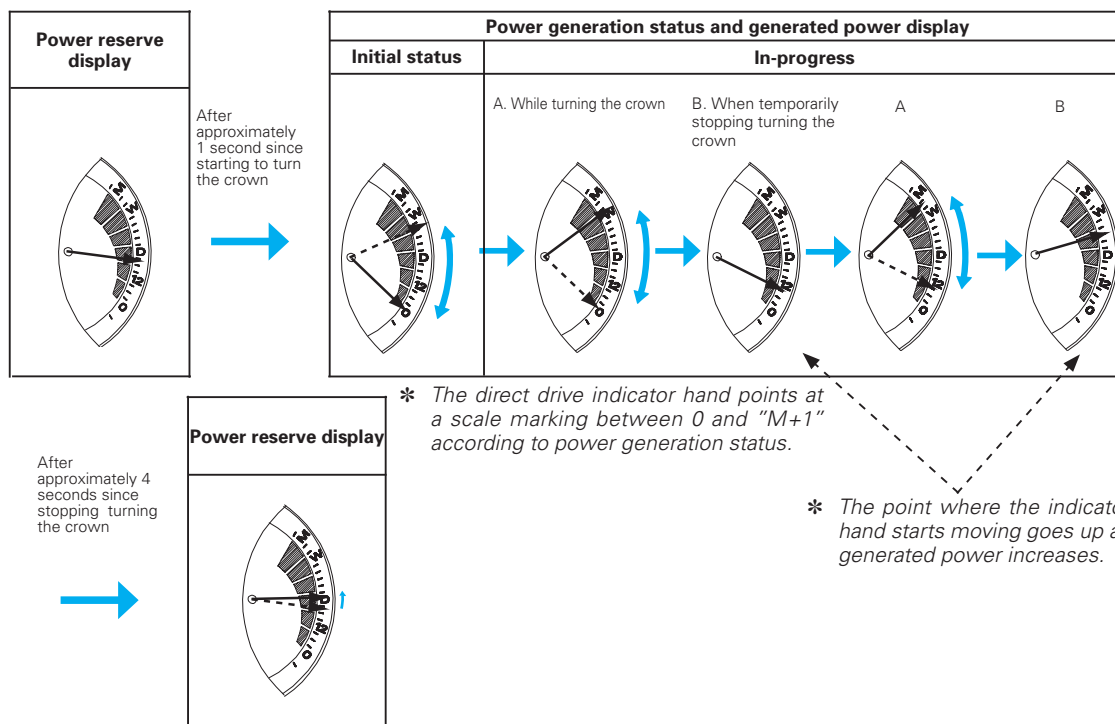

How to read the real-time power indicator

Scale marking	0	1	2	3	4	5	6	7	8	9	10
Indication on dial			0								D
Amount of generated power h=hour(s) min=minute(s)	Standby position		0	20 min	40 min	1h	1h 20 min	1h 40 min	2h	2h 20 min	2h 40 min

Scale marking		11	12	13	14	15	16	17	18	19	20
Indication on dial							W			M	
Amount of generated power h=hour(s) min=minute(s)		3h	3h 20 min	3h 40 min	4h	4h 20 min	4h 40 min	5h	5h 20 min	5h 40 min	6h

*note 1 When the watch is charged by any other method than manual winding, such as using KINETIC ENERGY SUPPLIER, the direct drive indicator hand may move in slightly slower motion.

*note 2 The direct drive indicator hand will stop at the maximum scale value pointing at the 'M+1' position. If the crown is turned after the direct drive indicator hand stops at the 'M+1' position, the watch continues to accumulate power reserve, but the real-time power indicator function stops. If you want to display the amount of generated power, stop turning the crown, and after the direct drive indicator hand returns to the power reserve display, start turning the crown again.

When the electric power is generated without interruption, for example when an electric charger is used, the direct drive indicator hand will stop and remain pointing at the 'M+1' position.

*note 3 After the direct drive indicator hand displays the accumulated amount of generated power, it returns to the power reserve display.

(Caution)

To enjoy the real-time power indicator function, power generation by manual winding is recommended as it enables you to check the power generating status.

BEFORE STARTING REPAIR WORK ON CAL. 5D22A

4. HOW TO REACTIVATE THE WATCH AFTER IT STOPPED

To reactivate the stopped watch, see the condition of the watch by following the steps below.

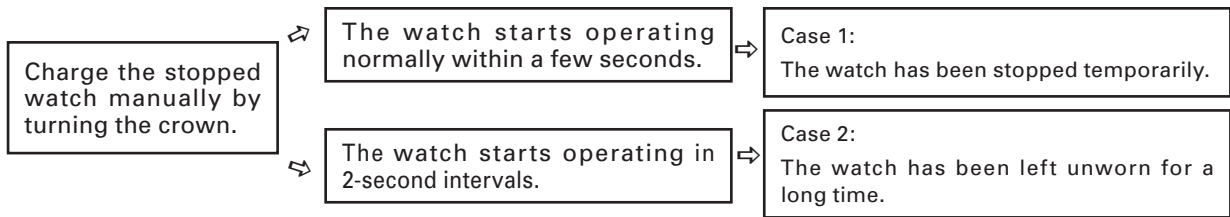

Case 1: The watch has been stopped temporarily.

The watch in this condition falls in the range shown by '1. The watch instantly starts moving' in the diagram below.

- The watch starts operating within a few seconds after you start turning the crown, and automatically correct the position of the direct drive indicator hand to the 0 position (0 indication on the dial).
- After the direct drive indicator hand returns to the 0 position, if no further power is generated subsequently, the watch will stop operating within three minutes.
- To prevent the watch from stopping during the subsequent procedures such as time setting and date setting, charge the watch at least until the direct drive indicator hand points at the first indication on the dial (3 hours of power reserve).

Case 2: The watch has been left unworn and stopped for a long time. (3 to 5 years or even more)

The watch in this condition falls in the range shown by '2. 2-second interval movement = The direct drive indicator hand does not move' in the diagram below.

When the voltage of the secondary battery is reduced to an extremely low level after the watch is left unworn for a long time, the watch moves in 2-second intervals after you start turning the crown until the voltage is increased to a reasonable level.

Charge the watch by manual winding method until the direct drive indicator hand returns to the 0 position from the standby position.

- If power generation is stopped while the watch is moving in 2-second intervals and before the direct drive indicator hand returns to the 0 position, the watch will stop operating within one minute.
- Estimated time required for manual winding to reactivate the watch in this condition: approximately 5 to 6 minutes

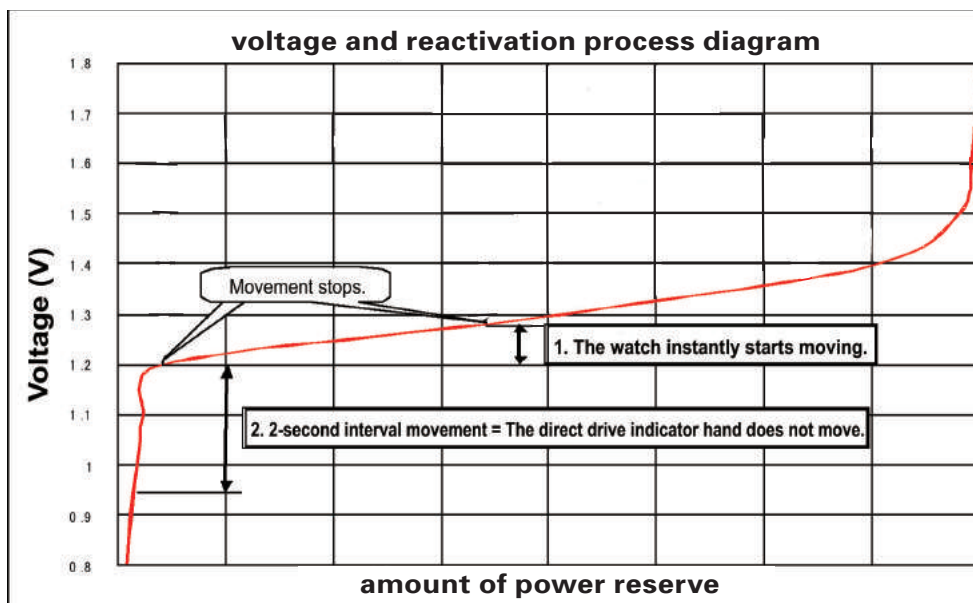

BEFORE STARTING REPAIR WORK ON CAL. 5D22A

5. HOW TO CHARGE THE WATCH WITH KINETIC ENERGY SUPPLIER YT-02A

Set the crown to the 5J position.

- Make sure that the watch is correctly positioned as it may affect the amount of power generated.
- The amount of power generated may vary depending the models of the watch.
- In some cases, the direct drive indicator hand does not move.
- If the direct drive indicator indicates a fully-charged status, the KINETIC ENERGY SUPPLIER will continue to charge the watch.

