



PARTS LIST/TECHNICAL GUIDE

ANALOGUE SOLAR Cal. V157A/V158A

[SPECIFICATIONS]

	Cal. No.	V157A/V158A
<div style="display: flex; justify-content: space-around;"> <div style="text-align: center;"> <p>V157A</p>  </div> <div style="text-align: center;"> <p>V158A</p>  </div> </div> <p style="text-align: center;">3 hands (hour, minute and second hands) date indicator/day indicator(only for V158A)</p>		<p>Movement</p>  <p style="text-align: center;">Diameter Outside: 28.6 mm Casing: 24.0 mm Height: 3.5mm</p>
Motion of the second hand		One-second intervals
Driving system		Stepping motor 1 piece
Additional function		Instart-start function Energy depletion forewarning function (The second hand moves at two-second intervals.) Overcharge prevention function Electronic circuit reset function Second hand stop function Date calendar Instant setting device for date calendar Day calendar (only for V158A) Instant setting device for day calendar (only for V158A)
Crown operation	Normal position	Free
	1st click position	Date setting(counter clockwise) Day setting (clockwise, only for V158A)
	2nd click position	Time setting
Loss/Gain		Monthly rate:less than 15 seconds (worn on the wrist at temperature range between 5 to 35 degrees Centigrade)
Regulation system		Nil
Gate time for rate measurement		Use 10-second gate
Current consumption		Movement: less than 0.80 μ A
		Circuit block: less than 0.40 μ A
Coil resistance		Coil block: 1.80 - 2.20 K Ω
Power supply	Power generator	Solar power generation system
	Rechargeable battery	MT920 Manganese titanium lithium rechargeable battery
	Operating voltage range	0.45V - 2.20V
	Power reserve	From full charge to stoppage: Approximately 10 months
Number of jewels		2 jewels

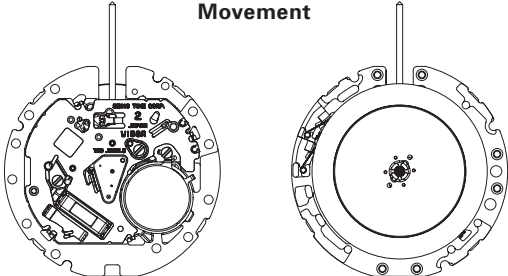
SEIKO WATCH CORPORATION

FEATURES

The Cal. V157A/V158A are analogue watches with a solar power generation system.

- Solar power generation system

The watch operates while charging electricity by converting light received on the dial to electrical energy. It lasts for 10 months after full charge.

- Energy depletion forewarning function

When the energy stored in the rechargeable battery is reduced to an extremely low level, the second hand starts moving at 2-second intervals instead of the normal 1-second intervals.

- Instant-start function

When the watch is exposed to sunlight or strong artificial light (of more than 1,000 lux), it will start operating immediately with the second hand moving at 2-second intervals.

- Guideline of charging time

Environment/Light source	Illumination (lux)	Time required for full charge	Time required for steady operation	Time to charge 1 day of power
General offices/ Fluorescent Light	700	-	25 hours	110 minutes
30W 20cm/Fluorescent light	3,000	120 hours	6 hours	30 minutes
30W 3cm/ Fluorescent light	10,000	35 hours	2 hours	10 minutes
Cloudy weather/Sunlight	10,000	35 hours	2 hours	10 minutes
Fair weather/Sunlight	100,000	9 hours	0.4 hours	2 minutes

The above table provides only a general guideline.

It is recommended that the watch be charged for as long as the charging time according to the column "Time required for steady operation" in this table in order to assure the stable movement of the watch.

- Caution for charging

When charging the watch, do not place it too close to a photo flash light, spotlight, incandescent light or other light sources as the watch temperature will become extremely high, causing damage to the parts inside the watch.

When exposing the watch to sunlight to charge it, do not leave it on the dashboard of a car, etc. for a long time, as the watch temperature becomes extremely high.



While charging the watch, make sure the watch temperature does not exceed 60 °C.

V158A is a caliber which improved standard accuracy and power reserve from V145A, and also available to be used for diver's watch.



V157A is a same caliber as V158A, but without a day calendar mechanism.

PARTS LIST

Cal. V157A/V158A

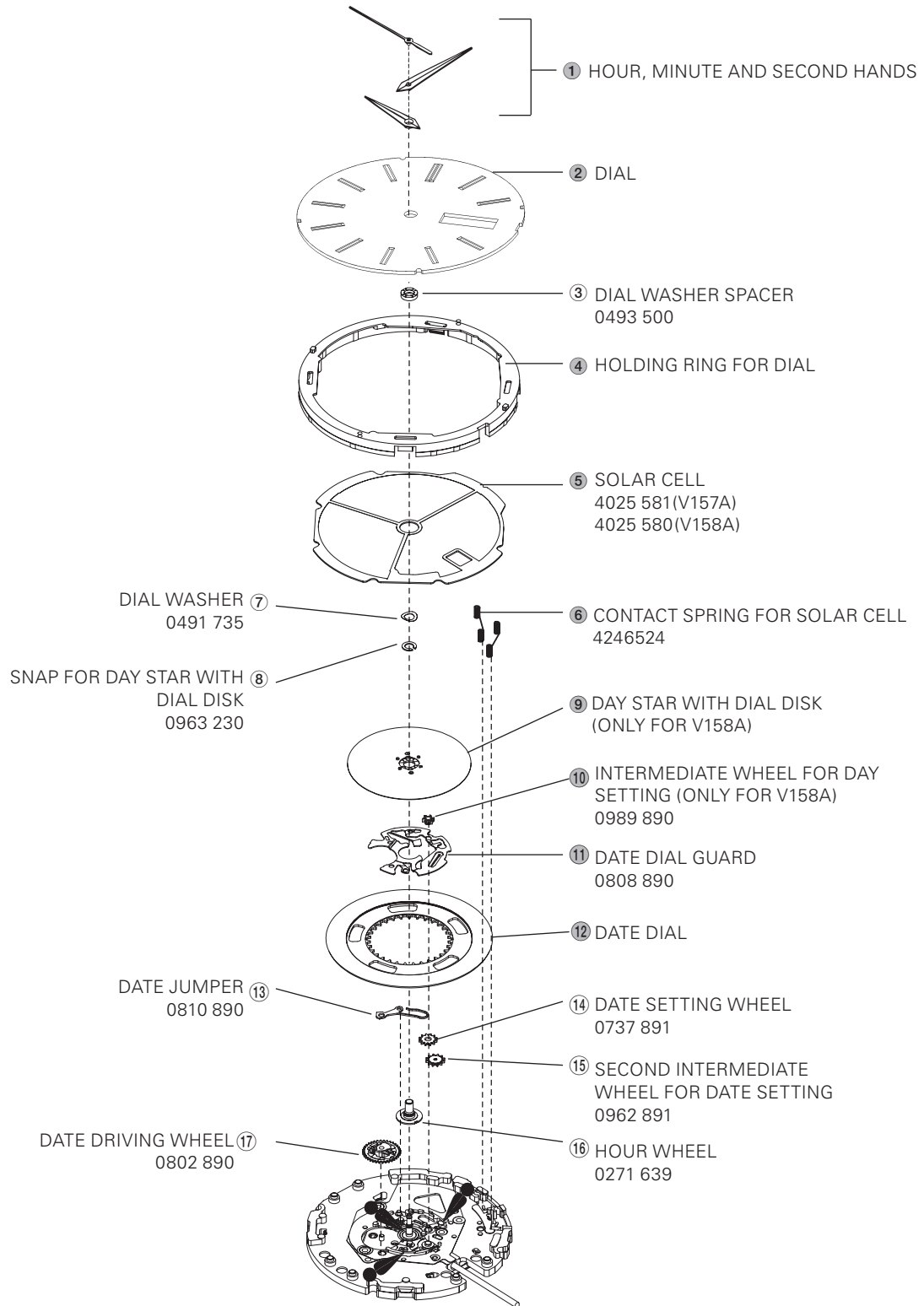
Order of disassembly: ① → ④①
 Order of assembly: ④① → ①
 Lubricating:
 Types of oil:  AO-3,  AO-2
 Oil quantity:  Normal quantity



  Please see the remarks on the following pages.

PARTS LIST

Cal. V157A/V158A

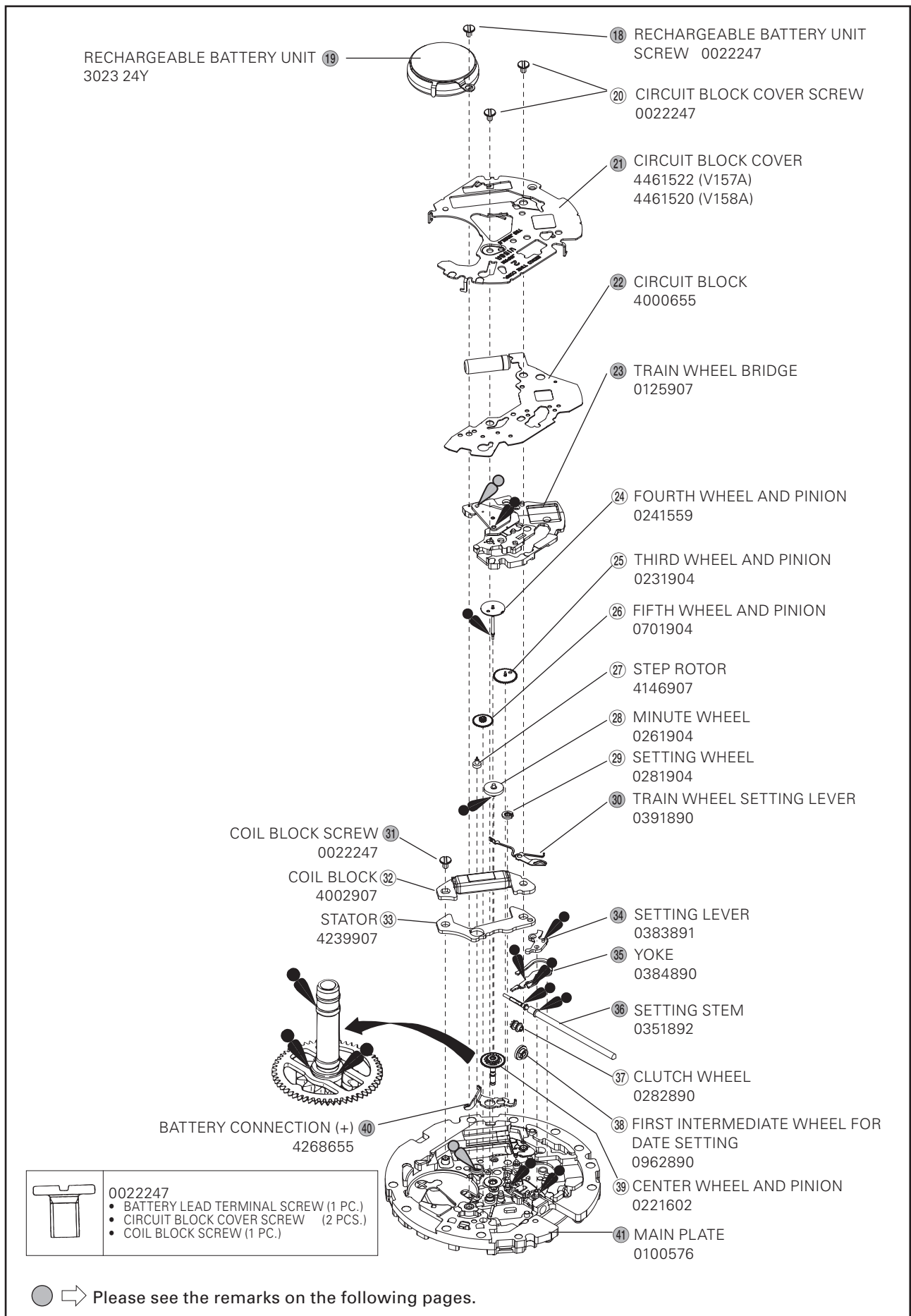

- 0022247
- BATTERY LEAD TERMINAL SCREW (1 PC.)
 - CIRCUIT BLOCK COVER SCREW (2 PCS.)
 - COIL BLOCK SCREW (1 PC.)

● ➡ Please see the remarks on the following pages.

PARTS LIST

Cal. V157A/V158A

● **How to find the correct parts, if not determined by 4 digit caliber number**

Following parts are determined based on the design of watches, such as hands height, dial color, and design of cases. Please refer to the SEIKO WATCH PARTS CATALOGUE in order to choose corresponding parts.

④ HOLDING RING FOR DIAL 0866855/0866861

The type of HOLDING RING FOR DIAL is determined based on the design of cases. Check the case number and refer to the "SEIKO WATCH PARTS CATALOGUE" to choose corresponding HOLDING RING FOR DIAL.

⑤ SOLAR CELL 4025581 (for V157A) 4025580 (V158A)

⑨ DAY STAR WITH DIAL DISK (only for V158A)

Parts number	Position of crown and calendar frame	Language	Color of figure	Color of background
0160565	3 o'clock	English/Spanish	Black	White
0160575	3 o'clock	English/Spanish	White	Black

The DAY STAR WITH DIAL DISK used differs depending on the casing model. Refer to the parts code number printed on the DAY STAR WITH DIAL DISK.

⑫ DATE DIAL

Parts number	Position of crown and calendar frame	Color of figure	Color of background
0878580	3 o'clock	Black	White
0878587	3 o'clock	White	Black

The type of DATE DIAL is determined based on the design of cases. Check the case number and refer to the "SEIKO WATCH PARTS CATALOGUE" to choose corresponding DATE DIAL.

⑯ SETTING STEM 0351892

The type of SETTING STEM is determined based on the design of cases. Check the case number and refer to the "SEIKO WATCH PARTS CATALOGUE" to choose corresponding SETTING STEM.

PARTS LIST

Cal. V157A/V158A

- **Tools and consumables required for disassembling/reassembling**

- **Movement holder**

UNIVERSAL MOVEMENT HOLDER (S-682)

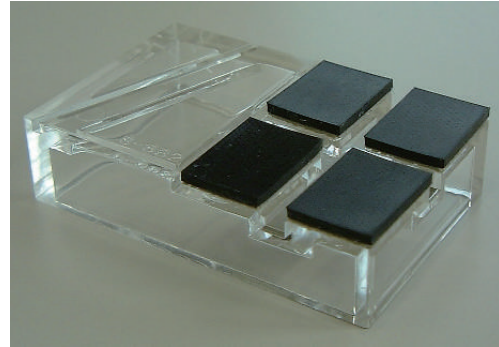

- **Watch oils**

SEIKO watch oils (AO-3 and AO-2)

AO-3



AO-2



REMARKS ON DISASSEMBLING AND REASSEMBLING

① HANDS

• How to install

Place the movement directly on a flat metal plate or the like to install the hands. In doing so, check that the spring portion of the circuit block cover is not pressed down.

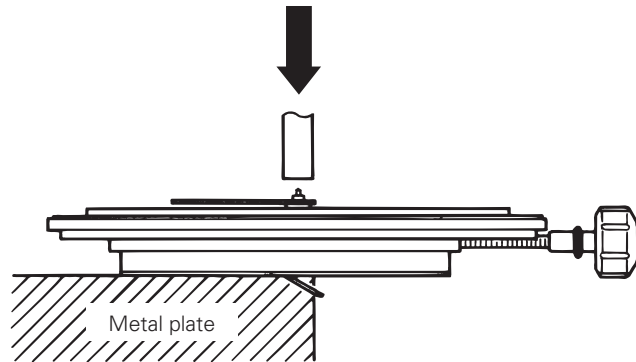

② DIAL

• How to install

Set the notched portions of the dial to the guide posts (4 posts) of the HOLDING RING FOR DIAL, and check that the dial is fixed in position.

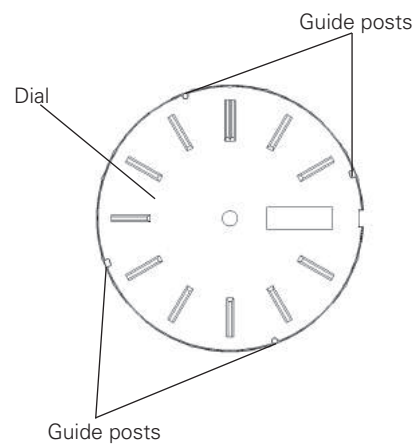

REMARKS ON DISASSEMBLING AND REASSEMBLING THE MOVEMENT

● HOW TO REMOVE THE SETTING STEM BEFORE DISMANTLING THE MOVEMENT

Crown position: normal position

Push the SETTING LEVER gently (refer to the Fig. 1) in order to disengage it from the SETTING STEM. Then pull out the crown with the stem completely.

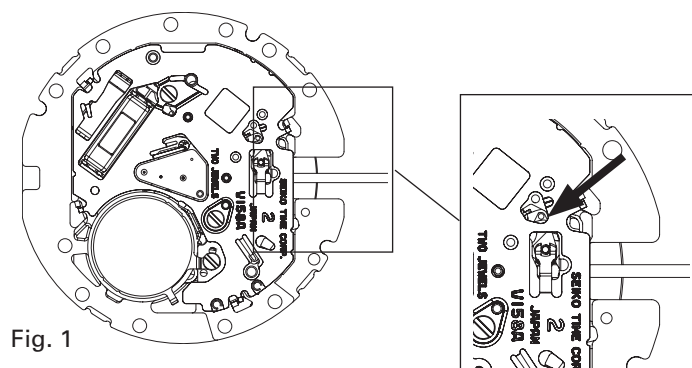

Fig. 1

④ HOLDING RING FOR DIAL

• Disassembling

1. The HOLDING RING FOR DIAL is fixed by 4 hooking portions.
2. Insert the tip of a screwdriver into the gap between the hooking portion and main plate as shown in the illustration, and then turn the screwdriver in the direction of the arrow to release the hooking portion from the main plate.

* It is not necessary to remove the SOLAR CELL from the HOLDING RING FOR DIAL.

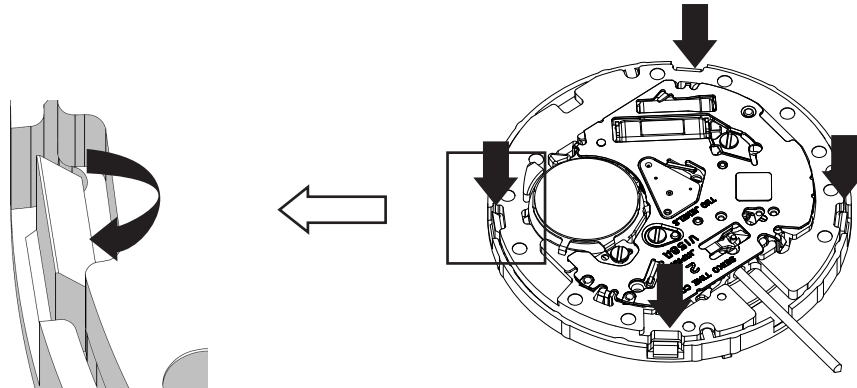

• Reassembling

1. Set the 4 hooking portions as shown in the illustration.
2. Gently push the HOLDING RING FOR DIAL above the hooking portions so that they catch the main plate securely.

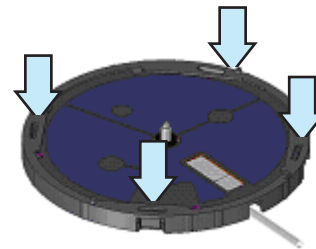

Notes:

- When installing the HOLDING RING FOR DIAL, take care not to damage or deform it.
- After installing the HOLDING RING FOR DIAL, check that all hooking portions catch the main plate securely.

• Disassembling and Reassembling of HOLDING RING FOR DIAL and SOLAR CELL

* It is not necessary to disassemble HOLDING RING FOR DIAL and SOLAR CELL except in the case that a part needs to be replaced.

<Disassembling>

As there are hooking portions at 12 o'clock and 6 o'clock sides, release them side by side.

<Assembling>

Gently push the SOLAR CELL at 12 o'clock and 6 o'clock sides.

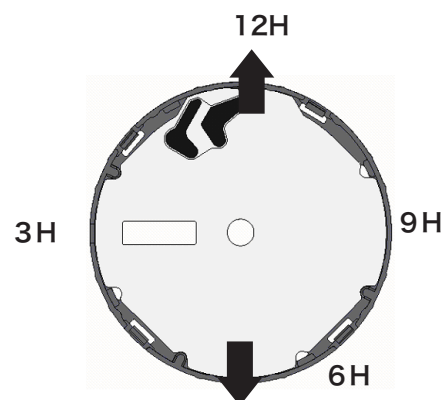

⑥ CONTACT SPRING FOR SOLAR CELL

Assemble the one side of spring to the main plate as shown in the illustration (white arrow), and then set the other side as shown in the illustration (black arrow)

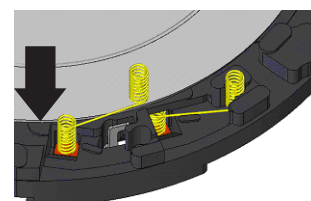

⑩ INTERMEDIATE WHEEL FOR DAY SETTING (only for V158A)

Please take care of the assembling direction of INTERMEDIATE WHEEL FOR DAY SETTING.

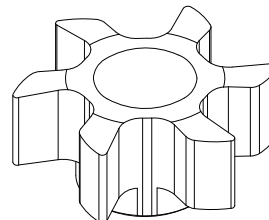

⑪ DATE DIAL GUARD

For the Cal. V157A and V158A, new assembling construction with 3 hooking portions and 2 guide pins are used.

• **Disassembling**

1. Remove the DATE DIAL GUARD from guide pin of A part by the tweezers as shown in the illustration, and turn the DATE DIAL GUARD counter-clockwise until it goes on to the guide pin.
2. Remove the DATE DIAL GUARD from guide pin of B part the same as A part.
3. After confirming that the 3 hooking portions on the main plate are removed from the DATE DIAL GUARD, remove it from main plate.

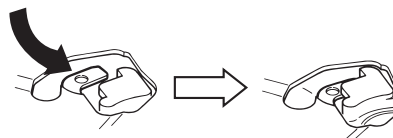
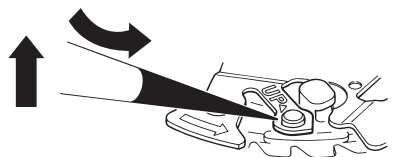
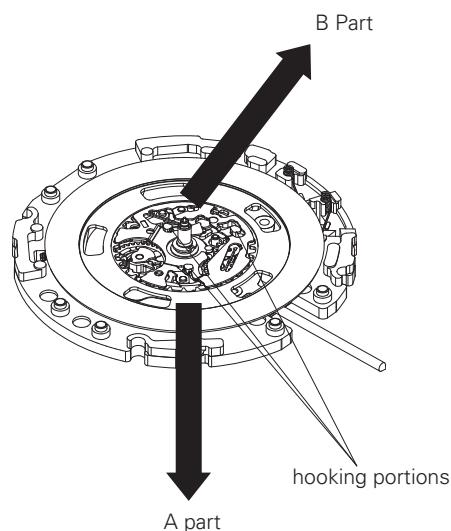

• **Assembling**

1. Put the DATE DIAL GUARD on the position which is shown in the illustration. Please put A and B parts on the guide pins.
2. Set the hooking portion of D part to the main plate by turning it clockwise.
3. Set the hooking portions of C and E part, and set A and B parts to the guide pins at the same time.
4. Check if the DATE DIAL GUARD is properly assembled to the main plate.

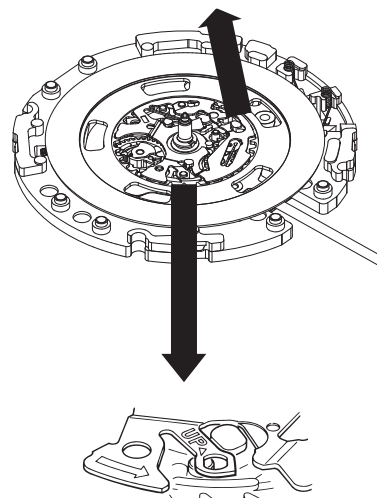

⑲ RECHARGEABLE BATTERY UNIT

• **How to remove**

Remove the battery lead terminal screw, and then pry up the "A" portion in the illustration with tweezers to remove the rechargeable battery unit.

• **How to install**

Set the "B" portion of the battery lead terminal to the guide hole of the main plate, and then push the center portion of the rechargeable battery unit (the "C" portion in the illustration) to fix it in position.

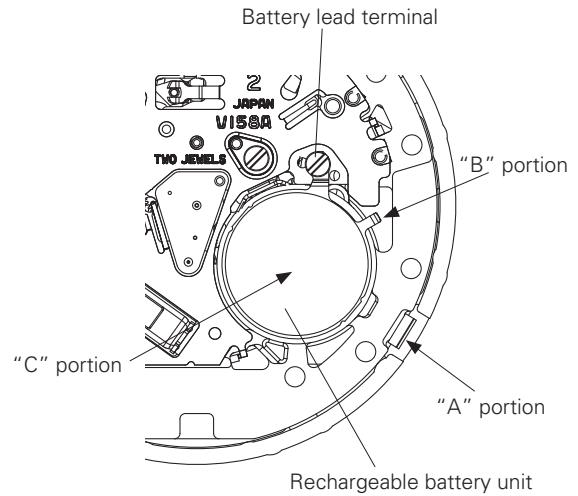

Notes:

- Be sure to observe the correct polarity of the rechargeable battery unit. The (-) side has the lead terminal.
- Handle the rechargeable battery unit with care so as not to short-circuit its (+) and (-) terminals.

⑳ TRAIN WHEEL BRIDGE

• **Setting position**

Refer to the illustrations below to check where to install the respective wheels.

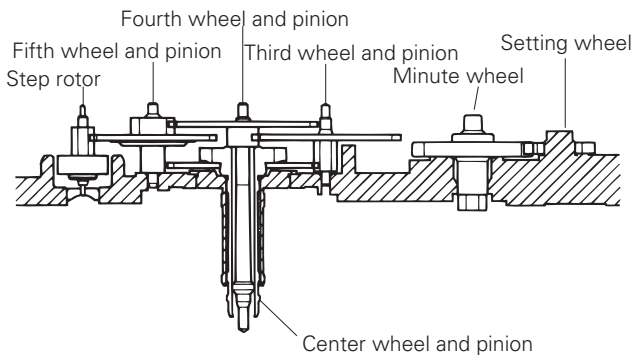
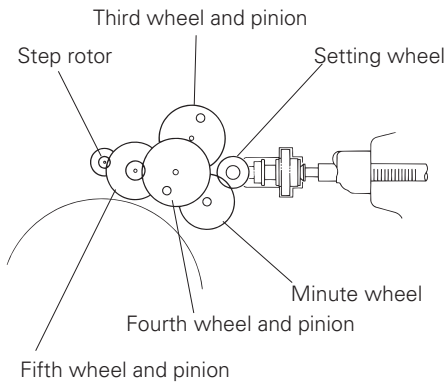

㉑ TRAIN WHEEL SETTING LEVER

㉒ SETTING LEVER

㉓ YOKE

• **Setting position**

Refer to the illustration at right.

㉔ SETTING STEM

The date corrector wheel has some elasticity in the contact with the winding stem so that it can be easily fixed.

Push in the winding stem straight toward the center of the main plate.

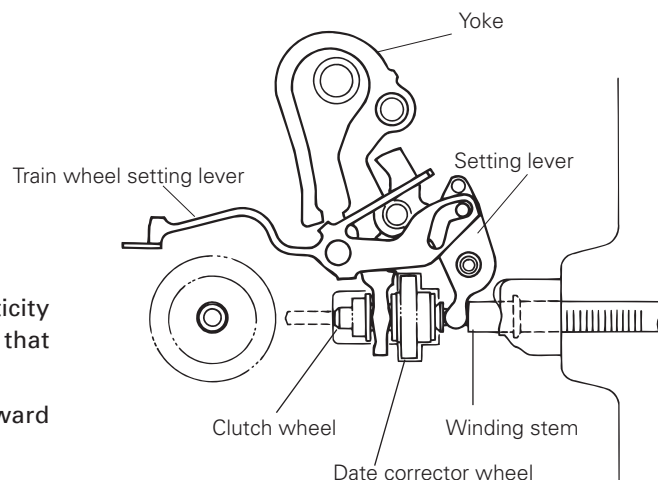

REMARKS ON INSPECTION AND MEASUREMENT

● CHECKING THE ELECTRICAL CHARACTERISTICS

<Coil resistance>

⑳ COIL BLOCK between 1.80 and 2.20 kΩ.

<How to measure the current consumption for the whole movement>

- 1) Remove the ⑤ SOLAR CELL and the ⑱ RECHARGEABLE BATTERY UNIT from the movement.
- 2) Tighten the ⑱ RECHARGEABLE BATTERY UNIT SCREW.
- 3) Connect the (-) probe to the (-) input terminal of the ⑱ RECHARGEABLE BATTERY UNIT SCREW and (+) probe to the ④ BATTERY CONNECTION (+) as illustrated in Fig. 2.

RECHARGEABLE BATTERY UNIT SCREW

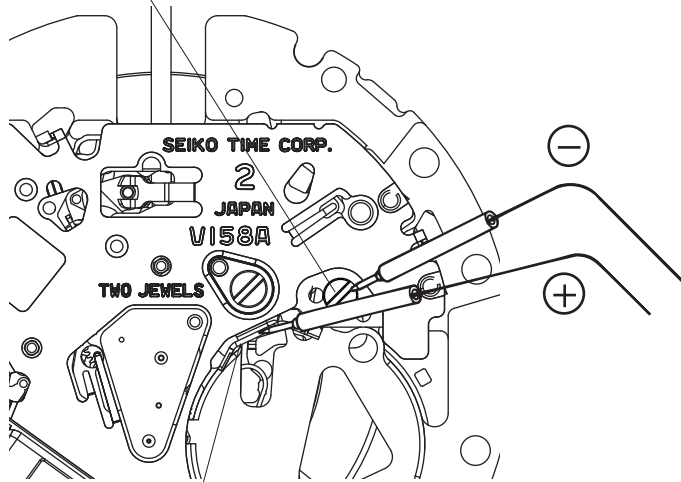
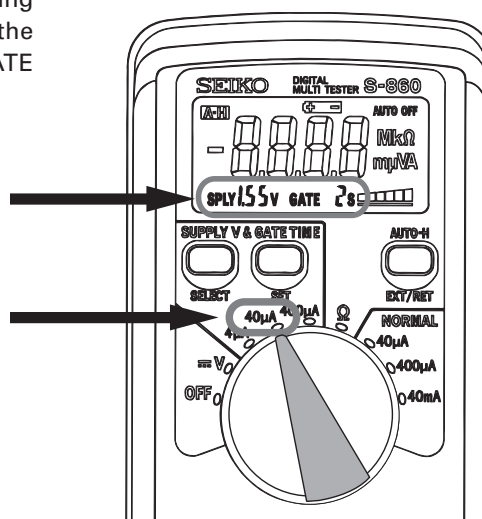

Fig. 2

BATTERY CONNECTION (+)

* When measuring the current consumption using the SEIKO digital multi-tester (S-860), use the range of 40μA of SUPPLY V (=1.55V) & GATE TIME (2S).



- 3) Wait until a stable measurement becomes available. It usually takes 30 seconds to a few minutes for getting a stable measurement.
- 4) Make sure that the read value is less than 0.80μA.

<How to measure the current consumption for the CIRCUIT BLOCK alone>

1) Connect each probe to the appropriate (-) and (+) input terminal of the ② CIRCUIT BLOCK (please refer to the "Structure of the CIRCUIT BLOCK" below).

- * When measuring the current consumption using the SEIKO digital multi-tester (S-860), use the range of 40 μ A of SUPPLY V (=1.55V) & GATE TIME (2S).
- * Avoid exposing the CIRCUIT BLOCK to direct light in order to obtain the correct measurement.

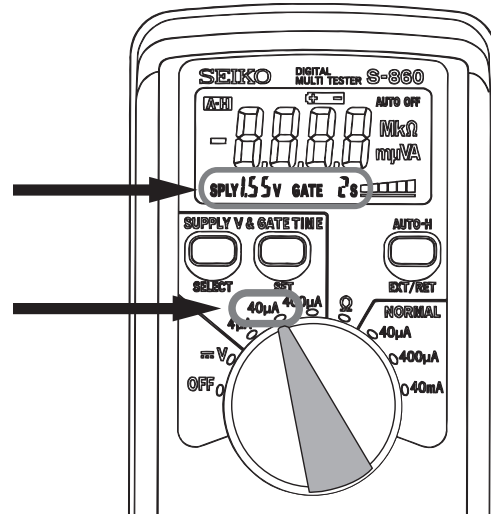

- 2) Wait until a stable measurement becomes available. It usually takes 30 seconds to a few minutes for getting a stable measurement.
- 3) Make sure that the read value is less than 0.40 μ A.

[Structure of the CIRCUIT BLOCK]

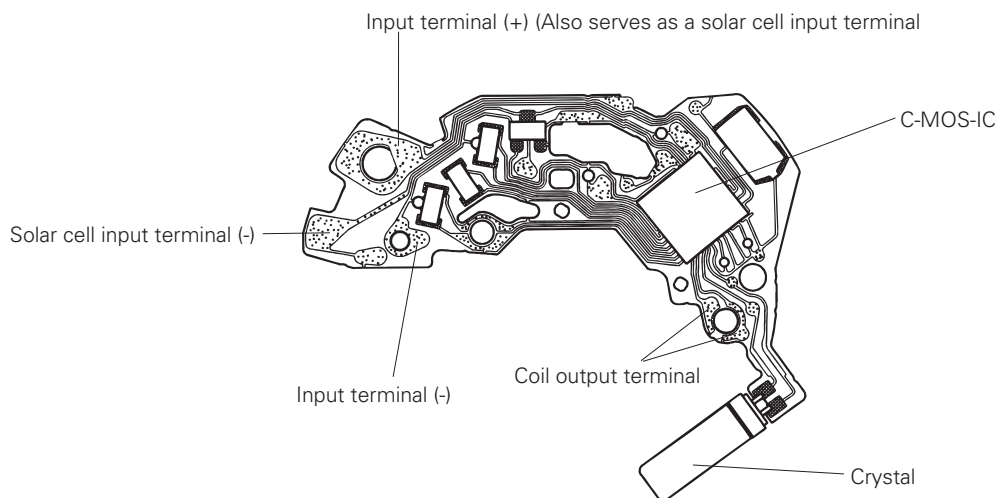

Note:

In case the measurement of the current consumption for a whole movement exceeds the standard value but the measurement for the circuit falls below the standard value, a problem in the gear train mechanism is suspected. Please disassemble and overhaul the movement and measure the current again.

● CHECKING THE SOLAR POWER GENERATION SYSTEM

<How to check the solar power generation with the watch>

- 1) Remove the ⑱ RECHARGEABLE BATTERY UNIT from the watch.
- 2) Pull out the crown to the 2nd click in order to reset the circuit.
- 3) Connect the (-) probe to the (-) input terminal for the ⑤ SOLAR CELL and (+) probe to the ⑳ CIRCUIT BLOCK COVER (as illustrated in Fig. 3).

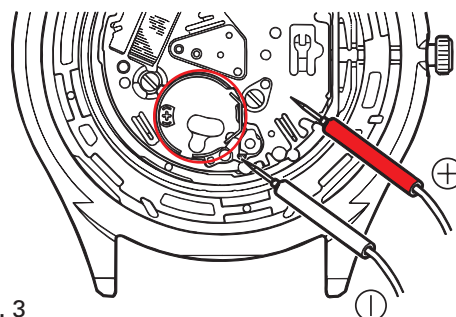

Fig. 3

- * When measuring the voltage using the SEIKO digital multi-tester (S-860), use the range of V (Fig. 4).

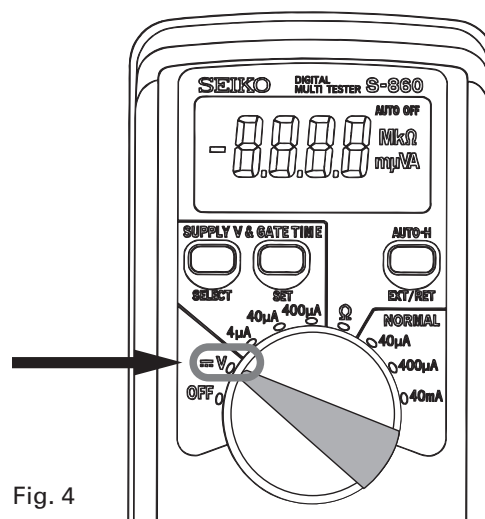

Fig. 4

- 4) Expose the watch to the light of a fluorescent lamp (use the one with 15 to 20 watts) at a distance of 5 cm while connecting the probes to the watch (Fig. 5).
- 5) Read the measurement and check if it exceeds 1.8 V.

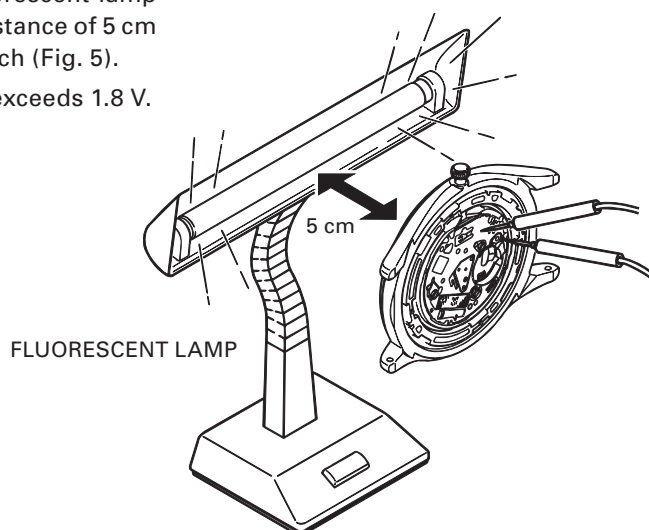
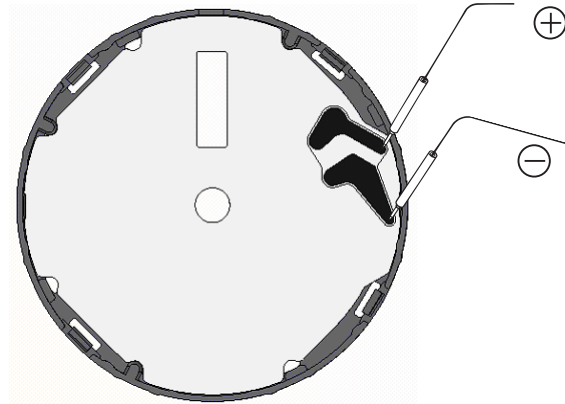

Fig. 5

<How to check the solar power generation with the SOLAR CELL alone>

- 1) Set the DIAL to the HOLDING RING FOR DIAL.
- 2) Connect the tester as the below illustration.



* When measuring the voltage using the SEIKO digital multi-tester (S-860), use the range of V (Fig. 6.)

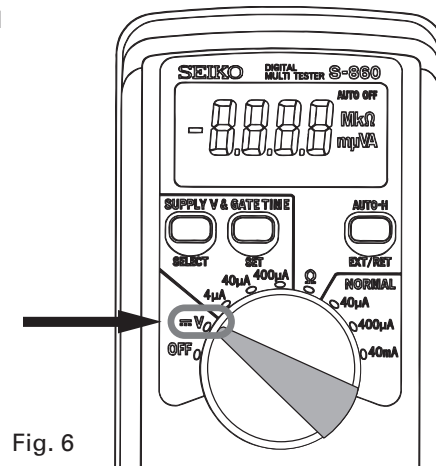

Fig. 6

- 2) Expose the SOLAR CELL to the light of a fluorescent lamp (use the one with 15 to 20 watts) at a distance of 5 cm while connecting the probes to the solar cell unit (Fig. 7.)
- 3) Read the measurement and check if it exceeds 1.8 V.

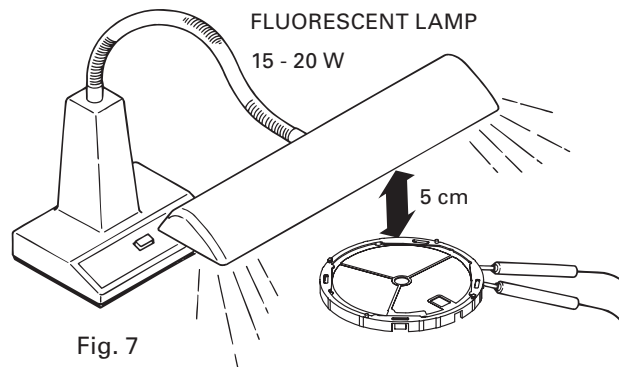

Fig. 7

Note: In case the measurement of the voltage for the watch does not achieve the standard value but the measurement for the solar cell unit alone exceeds the standard value, a problem in the electrical conductivity between the solar cell unit and the movement is suspected. Inspect the electrical conductivity, especially at the CONTACT SPRING FOR SOLAR CELL, and check the solar power generation system again.

● CHECKING THE INSTANT-START FUNCTION

The instant-start function works when the voltage of the rechargeable battery is more than 0.9V. Therefore, please measure the battery voltage and make sure that the battery is ready for checking the instant-start function.

- * When measuring the voltage of the rechargeable battery, connect the (-) probe to the RECHARGEABLE BATTERY UNIT SCREW and (+) probe to the ②1 CIRCUIT BLOCK COVER as illustrated in Fig. 8.

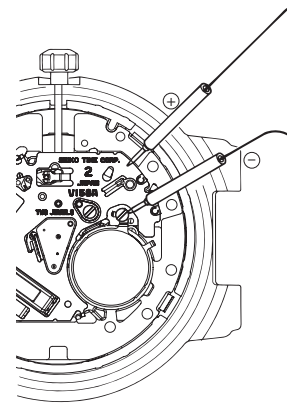

Fig. 8

<How to check the instant-start function>

- 1) Place the watch which stops working at a distance of 50 cm under the fluorescent lamp of 15 to 20 watts (Fig. 9.)
- 2) Check if the second hand of the watch starts moving at 2-second intervals within 10 seconds.

FLUORESCENT LAMP

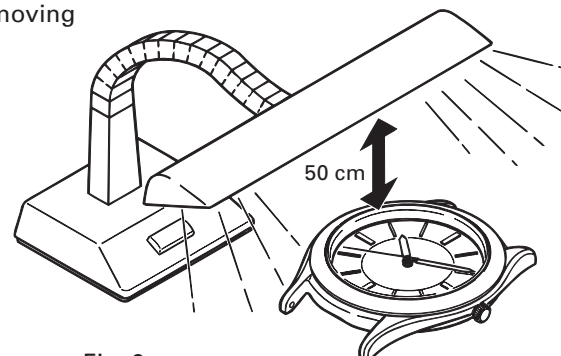

Fig. 9

● CHECKING THE RECHARGING FUNCTION

In order to check the recharging function, measure the voltage of the rechargeable battery before and after recharging. If the voltage increases to a certain extent, it shows that the recharging function is working properly.

- 1) Measure the voltage of the rechargeable battery before recharging (please refer to Fig. 8 of page 15 for where to apply the probes of the tester).
- 2) Recharge the watch by placing it at a distance of 5 cm under the fluorescent lamp of 15 to 20 watts for 30 minutes (Fig. 10.)

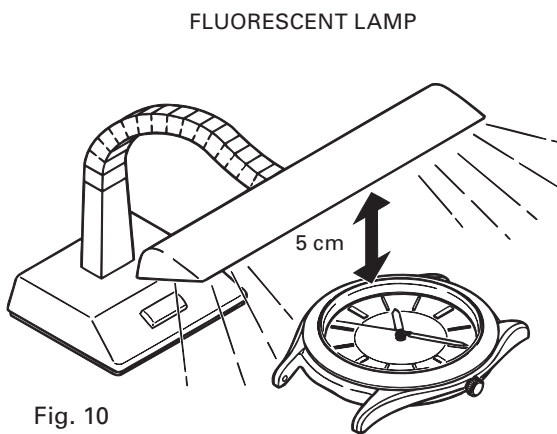

Fig. 10

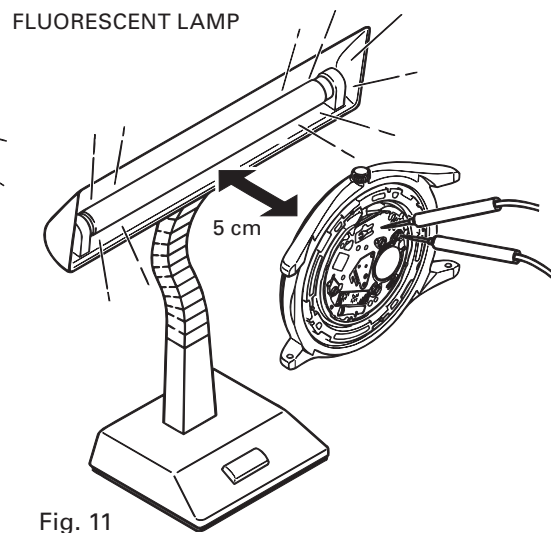

Fig. 11

- 3) Measure the voltage again while keeping the watch exposed to the light (Fig. 11.)
- 4) Compare the difference of the voltage before and after recharging. Refer to the table below for the criteria of the inspection.

Table - criteria recharging function Cal. V157A/V158A

The voltage BEFORE recharging	Results after recharging and criteria for checking the function	
	Recharging function works fine	The battery needs to be inspected and replaced if necessary
0.50V - 1.00V	More than 1.10V	Less than 1.09V
1.01V - 1.30V	Increased by 0.03V or more	Not increased or increased but not more than by 0.03V

● FUNCTION CHECK

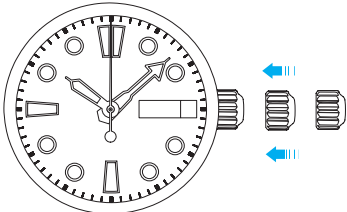
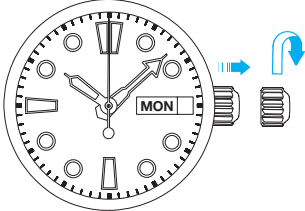
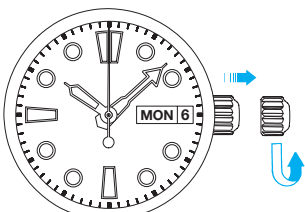
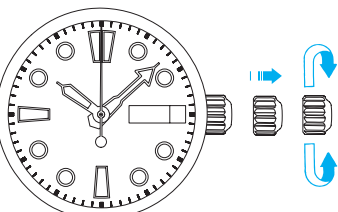



Operation	Function	Checkpoint
 <p>Pull out the crown to the 2nd click and push it back in to the normal position. Repeat the same several times.</p>	<p>Setting mechanism switching the function of the time setting.</p>	<p>Make sure that it has a click at each position and the stem is not pulled off.</p>
 <p>Pull out the crown to the 1st click, then turn it clockwise.</p>	<p>Calendar mechanism - correcting the day.</p>	<p>Make sure that the day changes smoothly.</p>
 <p>Pull out the crown to the 1st click, then turn it</p>	<p>Calendar mechanism - correcting the date.</p>	<p>Make sure that the date changes smoothly.</p>
 <p>Pull out the crown to the 2nd click, then turn it.</p>	<p>Second hand stop function.</p>	<p>Make sure that the second hand stops when the crown is pulled out to the 2nd click.</p>
	<p>Setting mechanism - hour and minute hand setting.</p>	<p>Make sure that the hour and minute hands move smoothly (without touching each other or touching the surface of the dial or inside of the glass).</p>
	<p>Hands installation.</p>	
<p>calendar mechanism - date change.</p>	<p>Make sure that the date changes when the hour and minute hands pass around midnight.</p>	

TECHNICAL GUIDE

Cal. V157A/V158A

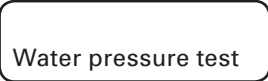
● CHECKING THE WATER RESISTANCE

Check the water resistance according to the designated specification of the watch.

Marking on the case back	Test method	Applied pressure
WATER RESISTANT (WATER RESIST)	Air leak test	3 BAR
WATER RESIST 5BAR	  	5 BAR
WATER RESIST 10BAR		10 BAR
WATER RESIST 15BAR		15 BAR
WATER RESIST 20BAR		20 BAR
SCUBA DIVER'S (AIR DIVER'S) 150 m	Condensation test	18.75 BAR = 150 (m) times 0.125
SCUBA DIVER'S (AIR DIVER'S) 200 m		25 BAR = 200 (m) times 0.125
He-GAS DIVER'S 300 m	Water pressure test	37.5 BAR = 300 (m) times 0.125
He-GAS DIVER'S 600 m		75 BAR = 600 (m) times 0.125
He-GAS DIVER'S 1000 m	Condensation test	125 BAR = 1000 (m) times 0.125

● CHECKING THE ACCURACY - INSTANTANEOUS RATE

Measure the rate and make sure the value shows within ± 0.50 s/d.

Use 10-second gate of the tester.