

MOVEMENT SPECIFICATIONS
CAL. 6P05/09/25/27/29/89 ANALOG QUARTZ MOV'T
 BY CITIZEN WATCH CO., LTD. JAPAN
MULTI - EYES RANGE
 MANUFACTURED IN JAPAN

1. BASIC SPECIFICATION

(1) CAL. NO.

CALIBRE	6P05	6P09	6P25	6P27	6P29	6P89
Ligne Size*mm	10-1/2 22.6 x 22.6 x Φ 23.3					
Total height	3.45mm					3.85mm
Hands	6	7	5	6		
Date	○					
Day of Week	○					
24 hour	X	○	X	○		
Month	○		X			○
Battery life	3Year					
Battery	SR621SW or equivalent					

(2) Time standard

Type of quartz : Tuning fork type quartz crystal
 Frequency : 32,768Hz
 Accuracy : **+/-20 s/month** worn under normal circumstances

(3) Battery installed

Type of battery : Silver oxide SR621SW or equivalent

(4) Others

Driving systems : Two-pole stepping motor

(5) Balanceable weight of hand

Minute hand Max. 0.4 μ N·m
 Second hand Max. 0.07 μ N·m

(6) Additional Mechanisms

Calendar : Date (Center, clockwise)
 Month (3 o'clock position, clockwise)
 Day (9 o'clock position, clockwise)

Date correction : Pull out the crown to the first click

Day correction : Pull out the crown to the second click

Month : Push button

Picture dial : Moon phase (Age of the moon dial rotating one turn every 59 days Φ 10.1mm)
 correction by pulling out the crown to the first click (clockwise)

Power conservation switch : Pull out the crown to the second click

Second hand stopping devis : Pull out the crown to the second click

2. SEPARATED PARTS

CALIBRE	6P05	6P09	6P25	6P27	6P29	6P89
Setting Stem	065-379					

* Setting stem 065-379
 Length of movement center to stem end... 20.03mm
 Thread..... $\Phi 0.9 \times 12.18\text{mm}$

3. Others

*** Measurement of time rate**

The unit(gate) time of measurement must be set at "10s " or integer fold value of 10s owing to the DFC system, and the measurement must be performed in the form of complete watch.

*** Marking on movement**

**MIYOTA CO. UNADJUSTED
 NO JEWEL JAPAN 6P50**

*** Typical clearance**

Mov't - Caseback minimum 150 μm or more
 Top of hands - Glass 300 - 400 μm *
 * depending and subject to the glass and case structure, and hand length

4. Notice Of Casing

- (1) The month corrector button should be hidden for preventing the error of action.
- (2) The returning pressure of the month corrector button should be Min.200g
- (3) The interval between Dial and Glass end should be 150 μm to avoid breakage under drop.

5.Setting Instructions

- (1) setting the day
 Set the day by pulling out the crown to second click position and rotating it forward (to rotate the hour and minute hands clockwise).
 If the day is set by rotating the crown backyard (rotating the hour and minute hands counter-clockwise), the date may not be changed.
 Note: The day is changed during the period from about 0:00 AM to about 5:30 AM
- (2) Setting the date (Quick change function)
 Pull the crown out to the first click position and set the date by rotating the crown backyard.
 If the date is set between 9:00 PM and 0:00 AM, the date will not change correctly.
- (3) Setting the normal time
 Pull the crown out to the second click position when the second hand reaches the 12 o'clock position so that the second hand stops there.
 Then set the hour and minute hands.
 When setting the minute hand, put it 4 to 5 minutes earlier than the time to be set, and then turn it back to the correct time.
 Note: The day is changed during the period from about 0:00 AM to about 5:30 AM.
 After the time is set, push the crown back simultaneously with the time signal.
 The second hand will start running at the same time.
- (4) Setting the month
 Each time the month setting button is pushed, the month is moved clockwise by one month. If the button is not pushed to the end, the month is not changed perfectly.
 Be sure to push it to the end firmly.
 The month changes at about 0:00 AM on the 1st day of the next month.
 Note: Do not change the month while the date hand lies between the 26th and the 31st.
 In this case, set the date hand out of this period to adjust the month after this operation, set the date hand again.
 When the time passes from a month with 30 or less days to a 31-day month, please correct the date hand. The month is also changed automatically.

This specifications might be changed without prior notice.

This drawing is provisional and subject to our reconfirmation and/or revision without notice.

xxx T1PW 6P25 (01) xxx (2100 1121) 00-07-25

DH5~DH6=22287 (±20)

Coordinates

Mark	X	Y	R
GM	0	0	—
DH5	-9759	6900	—
DH6	8251	-7500	—
a1	2351	11100	200
a2	7235	9131	200
a3	10800	3490	500
a4	10800	-3490	500
a5	3490	-10800	500
a6	-2700	-11100	200
a7	-5389	-10216	300
a8	-10800	-3490	500
a9	-10800	3490	500
a10	-3490	10800	500
b1	9591	6360	150
b2	7928	8331	150
b3	-5773	9946	150
b4	-7839	8415	150
b5	-9572	-6374	150
b6	-7916	-8342	150
b7	9196	-6906	150
b8	10501	-4690	150

	H
With Battery strap	3600
Without Battery strap	3450

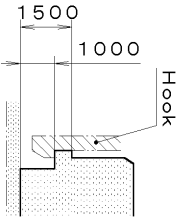
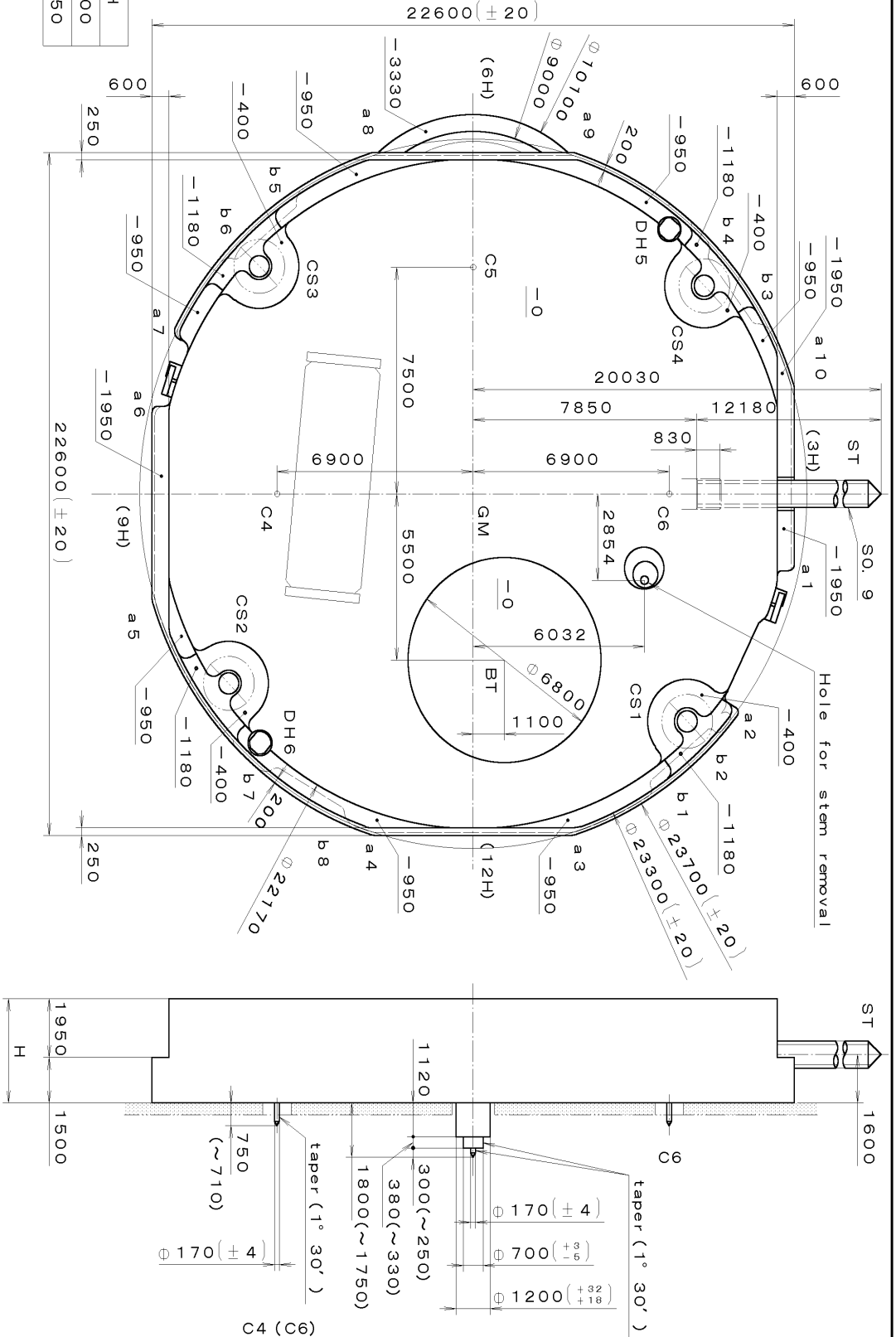

Section b1~b8

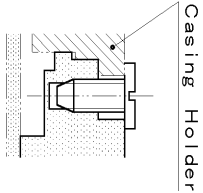

Section CS1~4

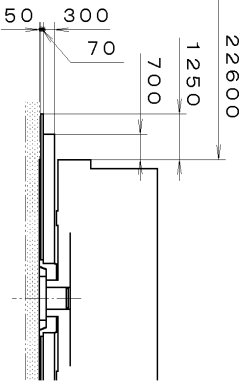

Section C5

Quantity	Unit	Scale	Cal. No. :
	1/1000 mm	7:1	6P25
			Parts:
			Name:
			Frame for Case
			Drawing No. : 6P25C0000
			Material
			Heat Treatment
			Hardness
			Plating
			General Tolerances
			Dimensions
			Angles

This drawing is provisional and subject to our reconfirmation and/or revision without notice.

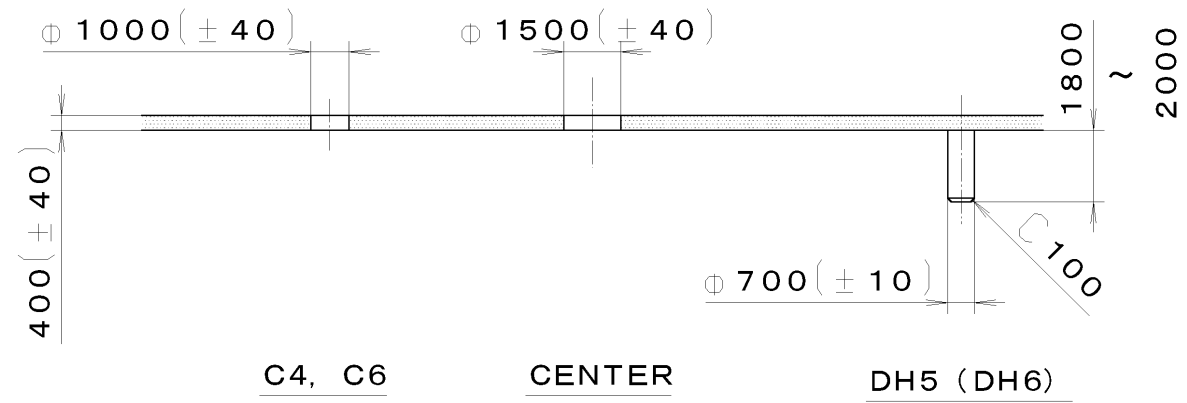
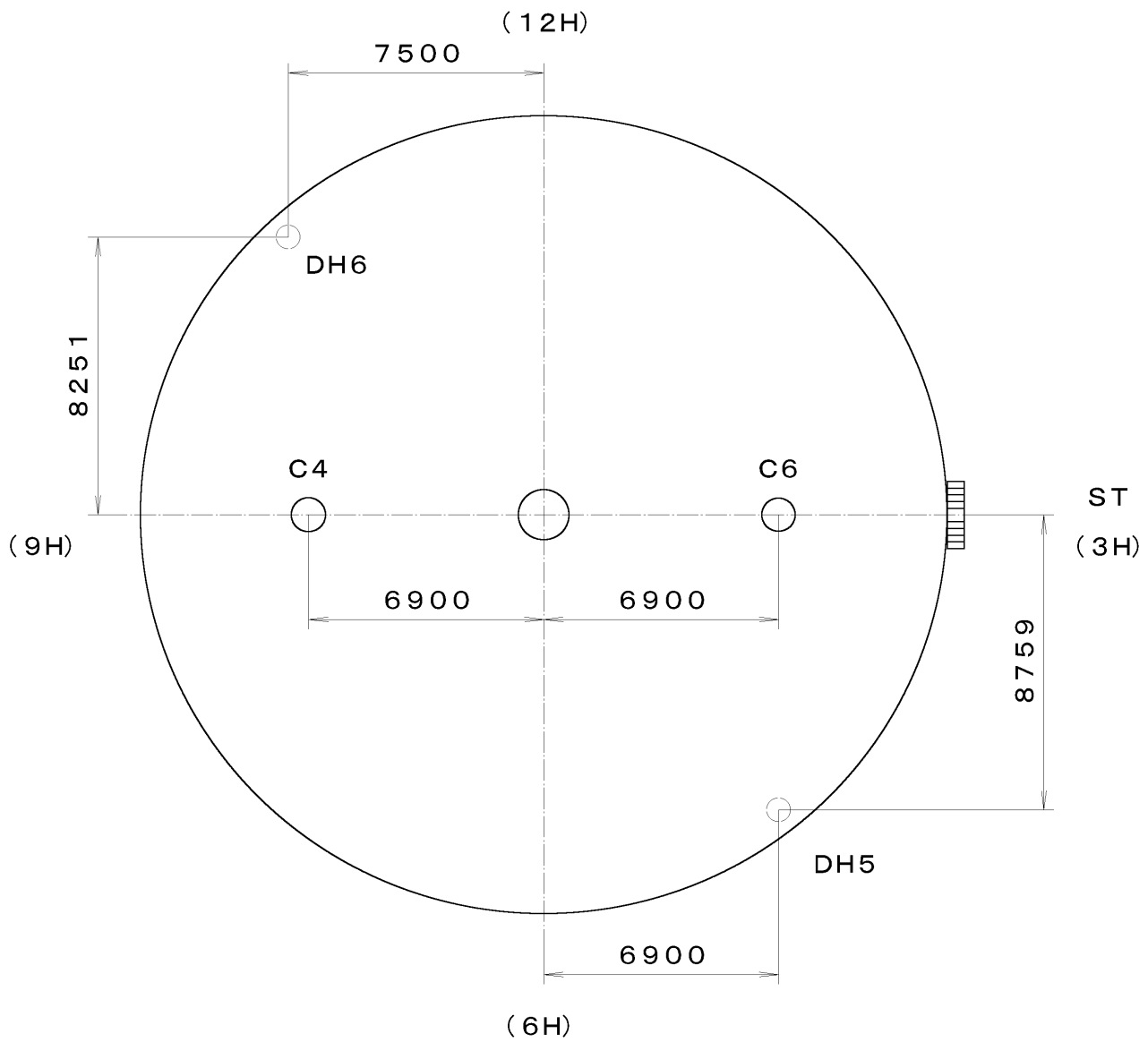

*** T I P W 6P25-00A (01) *** (2100 1121) 01-12-07

7		Quantity		Cal. No. :	6P25-00A
6		Unit	1/1000 mm	Parts:	
5		Scale	5:1	Name:	
4		Date		Indications for Dial	
3		Drawn		Drawing No. :	6P25D001
2		Checked	T. Hiruta		
1		Approved			
Material					
Heat Treatment		General Tolerances			
Hardness		Dimensions			
Plating		Angles			

This drawing is provisional and subject to our reconfirmation and/or revision without notice.

065-379 (01) *** (2100 1121) 00-06-23

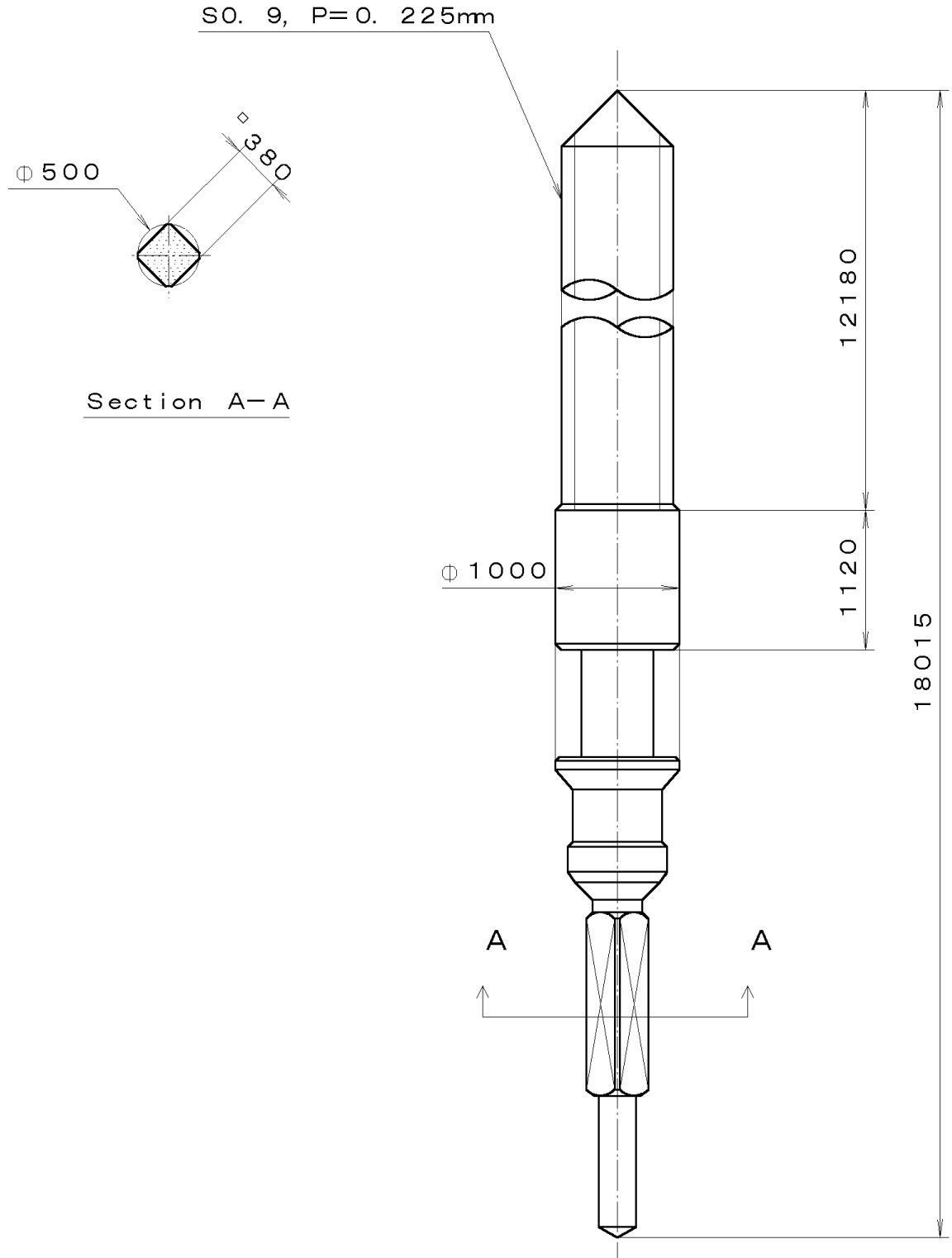

7		Quantity		Cal. No. :
6		Unit	1/1000 mm	Parts:
5		Scale	20:1	
4		Date		
3		Drawn		Name:
2		Checked	T. Hiruta	
1		Approved		SETTING STEM
Material				Drawing No. : 3790S000
Heat Treatment		General Tolerances		
Hardness		Dimensions		
Plating		Angles		