

MOVEMENT SPECIFICATIONS
CAL. 6P00/20/21/24/26 ANALOG QUARTZ MOV'T
 BY CITIZEN WATCH CO., LTD. JAPAN
MULTI - EYES RANGE
 MANUFACTURED IN JAPAN

1. BASIC SPECIFICATION

(1) CAL. NO.

CALIBRE	6P00	6P20	6P21	6P24	6P26
Ligne	'10-1/				
Size*mm	22.6 x 22.6 x Φ 23.3				
Total height	3.45mr				
Hands	6	5	5	3	4
Date	○	○	○	X	○
Day of Week	○	○	○	X	X
Moon Phase	○	○	○	○	X
moon phase color	BLUE	BLUE	BLUE	GREY	X
Month	○	X	X	X	X
Battery life	3Year				
Battery	SR621SV or equivalent				

(2) Time standard

Type of quartz : Tuning fork type quartz crystal
 Frequency : 32,768Hz
 Accuracy : **+/-20 s/month** worn under normal circumstances

(3) Battery installed

Type of battery : Silver oxide SR621SW or equivalent

(4) Others

Driving systems : Two-pole stepping motor

(5) Balanceable weight of hand

Minute hand Max. 0.4 μ N·m
 Second hand Max. 0.07 μ N·m

(6) Additional Mechanisms

Power conservation switch : Pull out the crown to the second click
 Second hand stopping device : Pull out the crown to the second click

2. SEPARATED PARTS

* Setting stem 065-379
 Length of movement center to stem end... 20.03mm
 Thread..... Φ 0.9 x 12.18mm

3. Others

*** Measurement of time rate**

The unit(gate) time of measurement must be set at "10s " or integer fold value of 10s owing to the DFC system, and the measurement must be performed in the form of complete watch.

*** Marking on movement**

6P**
MIYOTA CO. UNADJUSTED
NO JEWEL
JAPAN

*** Typical clearance**

Mov't - Caseback minimum 150 μ m or more
 Top of hands - Glass 300 - 400 μ m *

* depending and subject to the glass and case structure, and hand length

4. Notice Of Casing

- (1) The month corrector button should be hidden for preventing the error of action.
- (2) The returning pressure of the month corrector button should be Min.200g

5.Setting Instructions

- (1) setting the day (it can NOT be set by quick-adjustment.) (6P00,6P20,6P21)
 Set the day by pulling out the crown to second click position and rotating it forward (to rotate the hour and minute hands clockwise).
 If the day is set by rotating the crown backyard (rotating the hour and minute hands counter-clockwise), the date may not be changed.
 Note: The day is changed during the period from about 0:00 AM to about 5:30 AM

- (2) Setting the date (Quick change function) (6P00,6P20,6P21,6P26)
 Pull the crown out to the first click position and set the date by rotating the crown backyard.
 If the date is set between 9:00 PM and 0:00 AM, the date will not change correctly.





- (3) Setting the normal time (for ALL caliber)
 Pull the crown out to the second click position when the second hand reaches the 12 o'clock position so that the second hand stops there.
 Then set the hour and minute hands.
 When setting the minute hand, put it 4 to 5 minutes earlier than the time to be set, and then turn it back to the correct time.
 Note: The day is changed during the period from about 0:00 AM to about 5:30 AM.
 After the time is set, push the crown back simultaneously with the time signal.
 The second hand will start running at the same time.

- (4) Setting the month (6P00)
 Each time the month setting button is pushed, the month is moved clockwise by one month. If the button is not pushed to the end, the month is not changed perfectly. Be sure to push it to the end firmly.
 The month changes at about 0:00 AM on the 1st day of the next month.
 Note: Do not change the month while the date hand lies between the 26th and the 31st. In this case, set the date hand out of this period to adjust the month after this operation, set the date hand again.
 When the time passes from a month with 30 or less days to a 31-day month, please correct the date hand. The month is also changed automatically.

- (5) Reading and setting the age of the moon. (6P00,6P20,6P21,6P24)

Age of the moon

The age of the moon is determined by the period between each new moon. This period is approximately 29.5days.

New Moon Moon's age : 0 Spring tide	First quarter moon Moon's age : 7 Neap tide	Full moon Moon's age : 15 Spring tide	Last quarter moon Moon's age : 22 Neap tide
			

** index of moon age

The moon dial represents the age of the moon: The actual shape of the moon during each phase is not represented.

Use the moon dial indication as a guide to the age or phase of the moon

Setting age of the moon

Check the newspaper or another source that lists the current age of the moon.

Referring to above **index , set the moon dial to the age (0,7,15 or 22) closest to that index position.

More accurate settings can be made at the time of the new moon (0) or full moon (15)

This specifications might be changed without prior notice.

This drawing is provisional and subject to our reconfirmation and/or revision without notice.

*** TIPW 6P26 (01) *** (2100 1121) 03-01-30

DH5~DH6=22287 (±20)

Coordinates

Mark	X	Y	R
GM	0	0	—
DH5	-8758	6900	—
DH6	8251	-7500	—
a1	2351	11100	200
a2	7235	9131	200
a3	10800	3490	500
a4	10800	-3490	500
a5	3490	-10800	500
a6	-2700	-11100	200
a7	-5389	-10216	300
a8	-10800	-3490	500
a9	-10800	3490	500
a10	-3490	10800	500
b1	9581	6360	150
b2	7928	8331	150
b3	-5773	9946	150
b4	-7939	8415	150
b5	-9572	-6374	150
b6	-7916	-8342	150
b7	9196	-6306	150
b8	10501	-4690	150

	H
With Battery strap	3600
Without Battery strap	3450

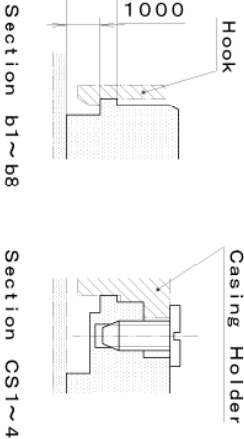
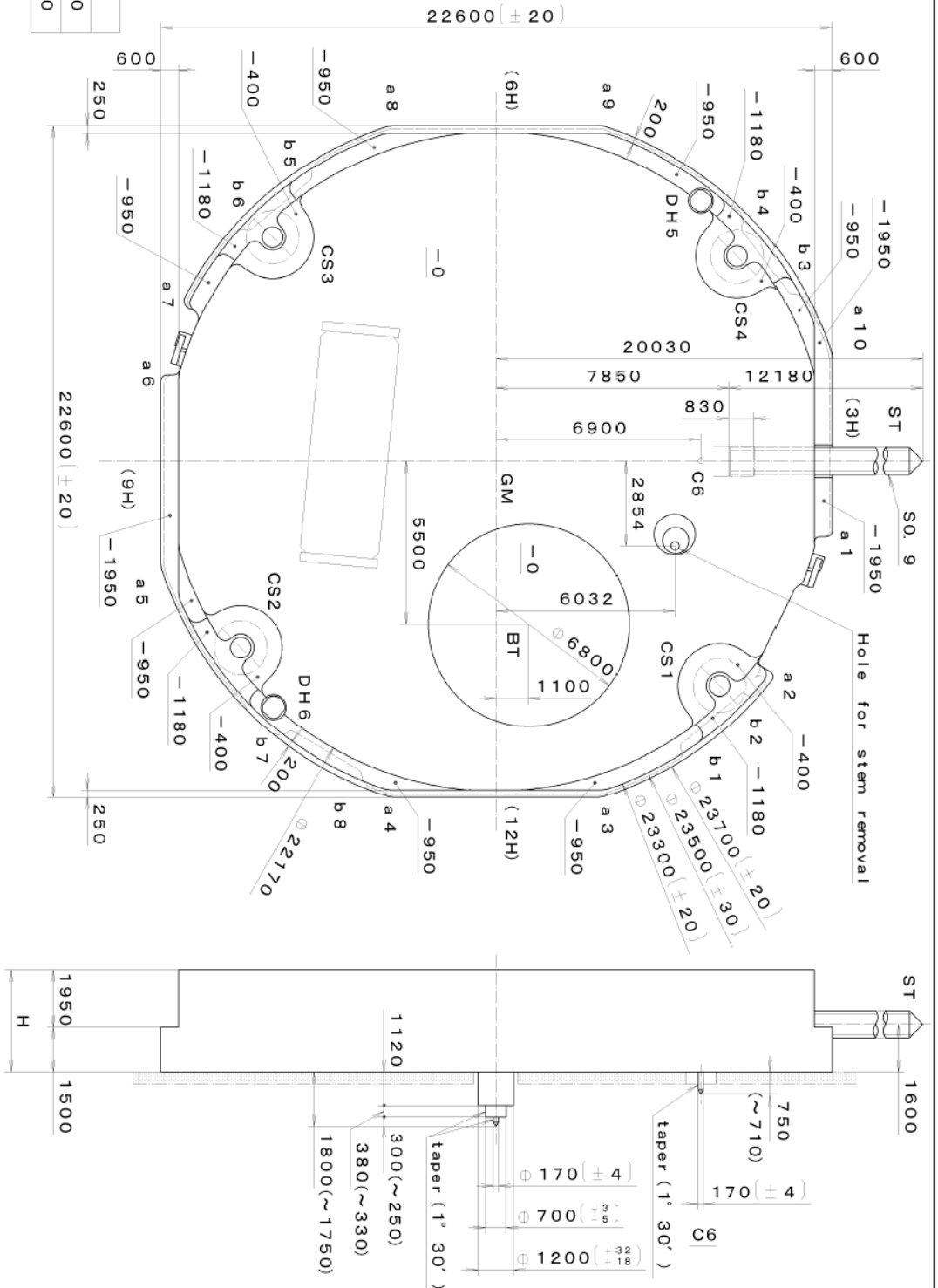

Quantity	Unit	Cal. No. :
1	1/1000 mm	6P26
Scale	7:1	Parts:
Date		Drawn
Checked	T. Hiruta	Checked
Approved		Approved
Material		Name: Frame for Case
Heat Treatment		Drawing No. : 6P26C000
Hardness		
Plating		
General Tolerances		
Dimensions		
Angles		

This drawing is provisional and subject to our reconfirmation and/or revision without notice.

03-01-27

(2100 1121)

5P26-00A

*** T.I.P.W

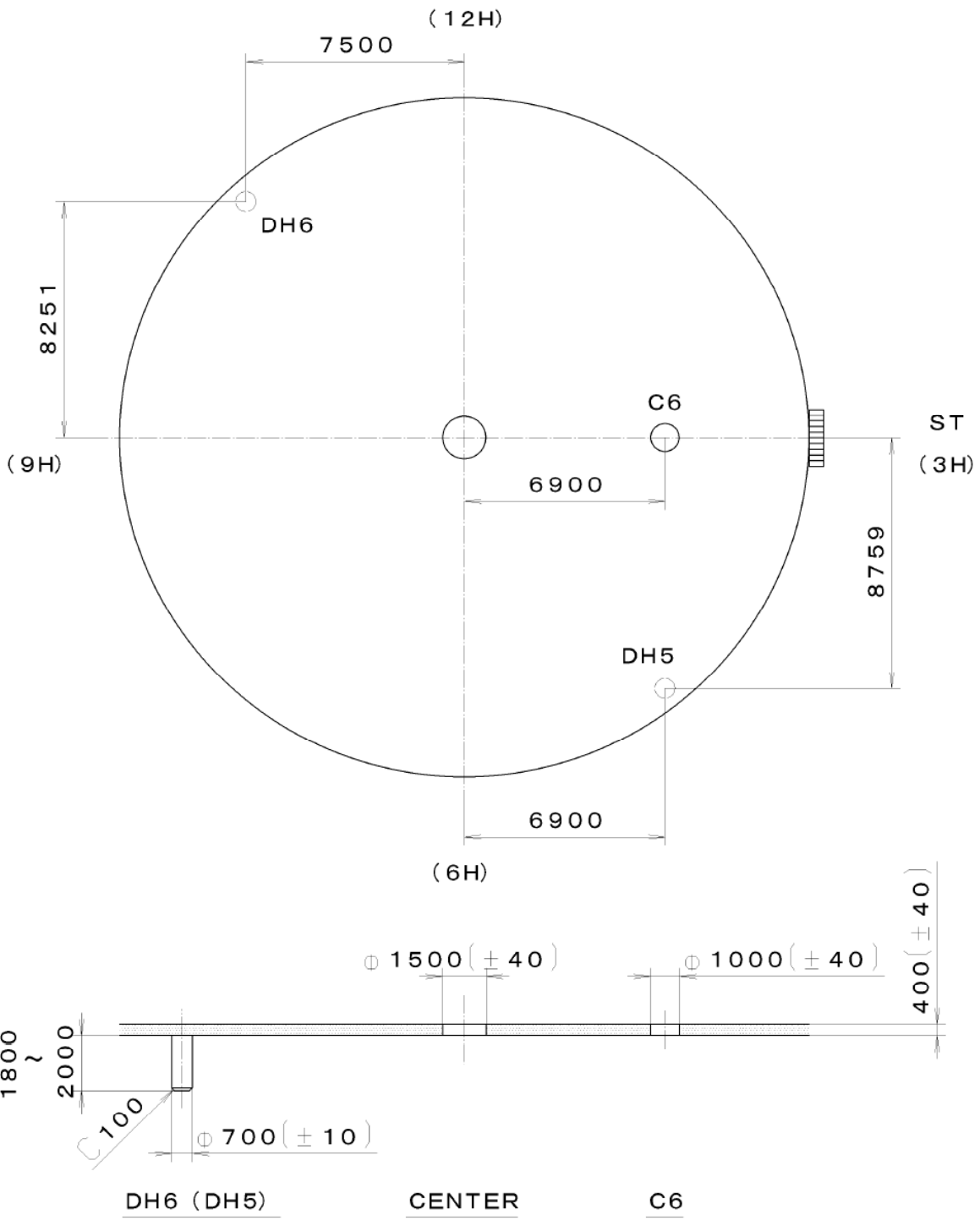

△		Quantity	Cal. No. : 6P26-00A
△		Unit	1/1000 mm
△		Scale	5:1
△		Date	Parts:
△		Drawn	Name:
△		Checked	T. Hiruta
△		Approved	Indications for Dial
Material		Drawing No. : 6P26D000	
Heat Treatment		General Tolerances	MIYOTA
Hardness		Dimensions	
Plating		Angles	

This drawing is provisional and subject to our reconfirmation and/or revision without notice

00-06-23
 (2100-1121)
 (01) KKK
 C.65-379
 KKK T.I.P.W.

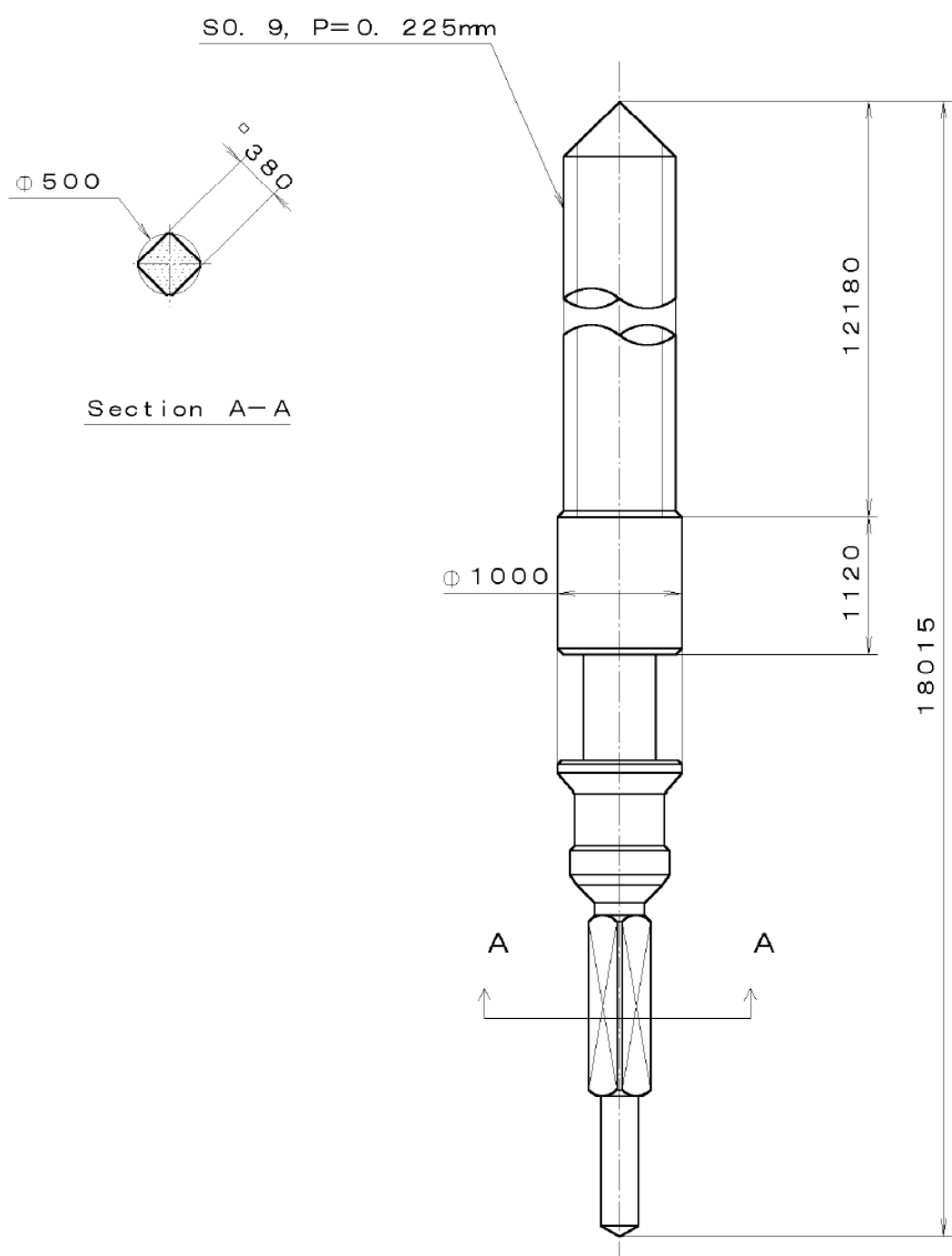

Material		Quantity		Cal. No. :	
Heat Treatment		Unit 1/1000 mm		Parts:	
Hardness		Scale 20:1		065-379	
Plating		Date		Name :	
		Drawn		SETTING STEM	
		Checked T. Hiruta		Drawing No. : 3790S000	
		Approved			
		General Tolerances		MIYOTA	
		Dimensions			
		Angles			