

MIYOTA

Cal. JS20 / JS55

STOPWATCH



1. Basic Specification

Calibre	JS20	JS55
Ligne	12 1/2	
Overall diameter	Φ28.2 × 26.0 (3H-9H)	
Case fitting diameter	Φ27.6 × 26.0 (3H-9H)	
Total height	4.18mm	
Date	×	
Battery Life	Approx.2years * 30minutes chronograph operation per day	
Battery	SILVER OXIDE SR621SW or equivalent	

< Time Standard >

Type of quartz: Tuning fork type quartz crystal

Frequency : 32,768Hz

Accuracy : ±20 second / month worn under normal circumstances

< Balanceable weight of hand >

Minute hand Max. 0.4 μN.m

Second hand Max. 0.09 μN.m

Other small hands Max. 0.02 μN.m

< Function >

Stopwatch 1 sec. basis (Up to 29 min. 59 sec.)

Powercell Saving Reset Mechanism(PSRM)

Over-loading Compensation Device(OLCD)

Digital Frequency Control(DFC) for time adjustment

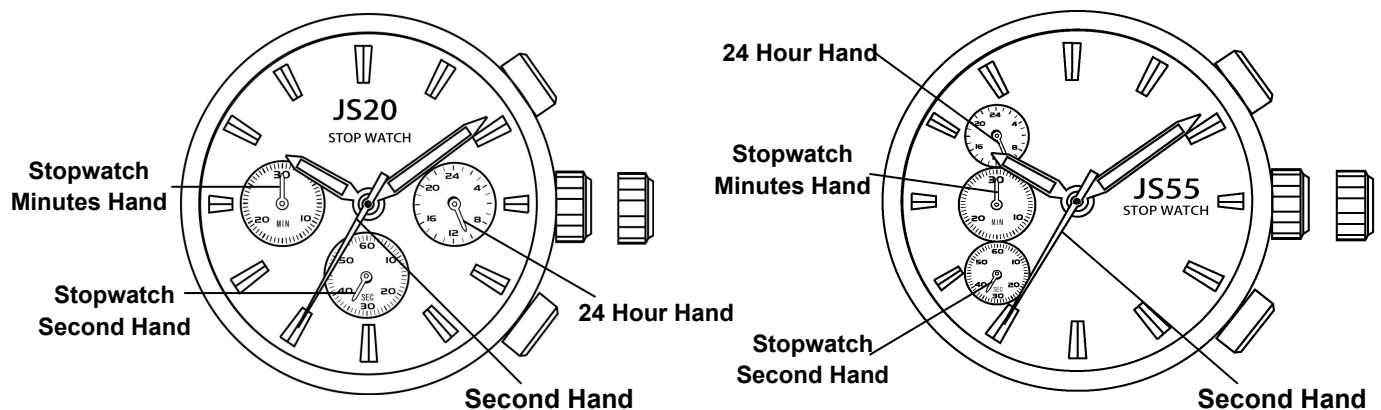

2. Separated Parts

Setting stem	065- 505 × 1
Length from movement center to far end of setting stem	20.03mm
Thread	Φ 0.9mm × 11.68mm

3. Others

* Measurement of time rate

The unit(gate) time of measurement must be set at "10 sec." or integer fold value of 10 sec. Owing to the DFC system, and the measurement must be performed in the form of complete watch.

* Marking on movement

JAPAN
MIYOTA CO.
(CAL. NO.)
NO JEWELS

* Typical clearance

Mov't - Caseback minimum 150 microns
Top of hands - Glass 300 - 400 microns *

* subject to the glass, case structure, and the length of hand

4. Instruction Manual

【Displays and Buttons】

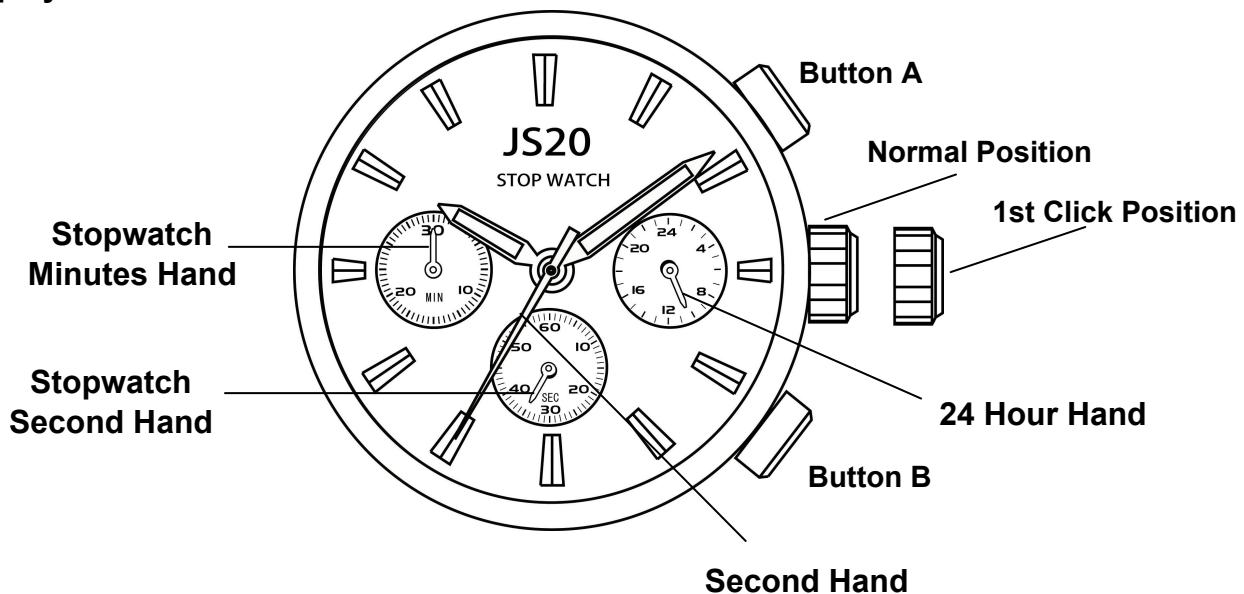

A) SETTING THE TIME

1. Pull the crown out to the 1st Click Position.
2. Turn the crown to set hour and minute hands.

B) USING THE STOPWATCH

This stopwatch is able to measure and display time in 1/1 second united up to maximum of 30 minutes. Stopwatch will stop automatically after running continuously for 30 minutes.

【Measuring time with the stopwatch】

1. Press button "A" to start the stopwatch.
2. The stop watch can be started and stopped each time button "A" is pressed.
3. Pressing button "B" resets the stopwatch and stopwatch minute and second hands return to their Zero positions.

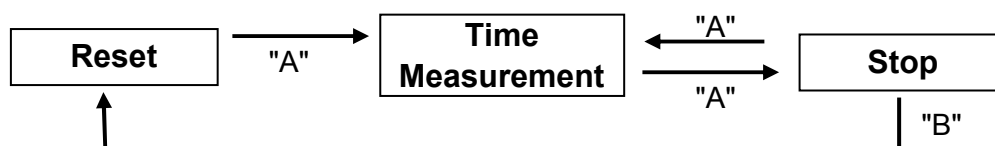

C) STOPWATCH RESET (INCL. AFTER REPLACING BATTERY)

This procedure should be performed when the stopwatch second hand does not return to the Zero second.

1. Pull the crown out to the 1st Click Position.
2. Press the button "A" once to set the stop watch second hand to the Zero position.
 - * The stopwatch minutes hand is synchronized with stop watch second hand.
 - * The stopwatch second hand can be advanced rapidly by continuously pressing button "A".
3. Once the hands been zeroed, reset the time and return the crown to its normal position.

These specifications might be changed without prior notice.

CITIZEN WATCH CO., LTD.

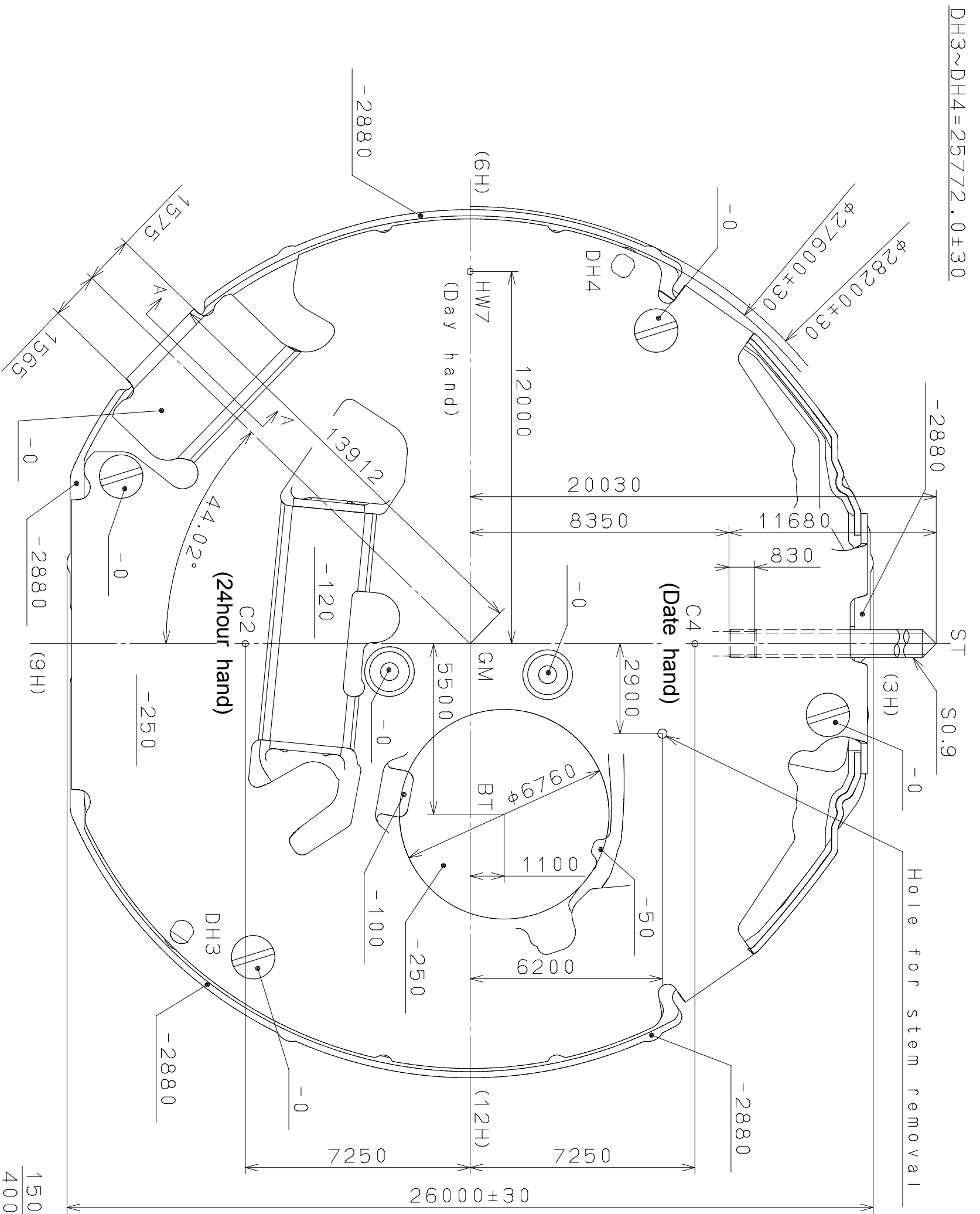

Coordinates

記号	X	Y
GM	0	0
DH3	9298	-9298
DH4	-12192	4926

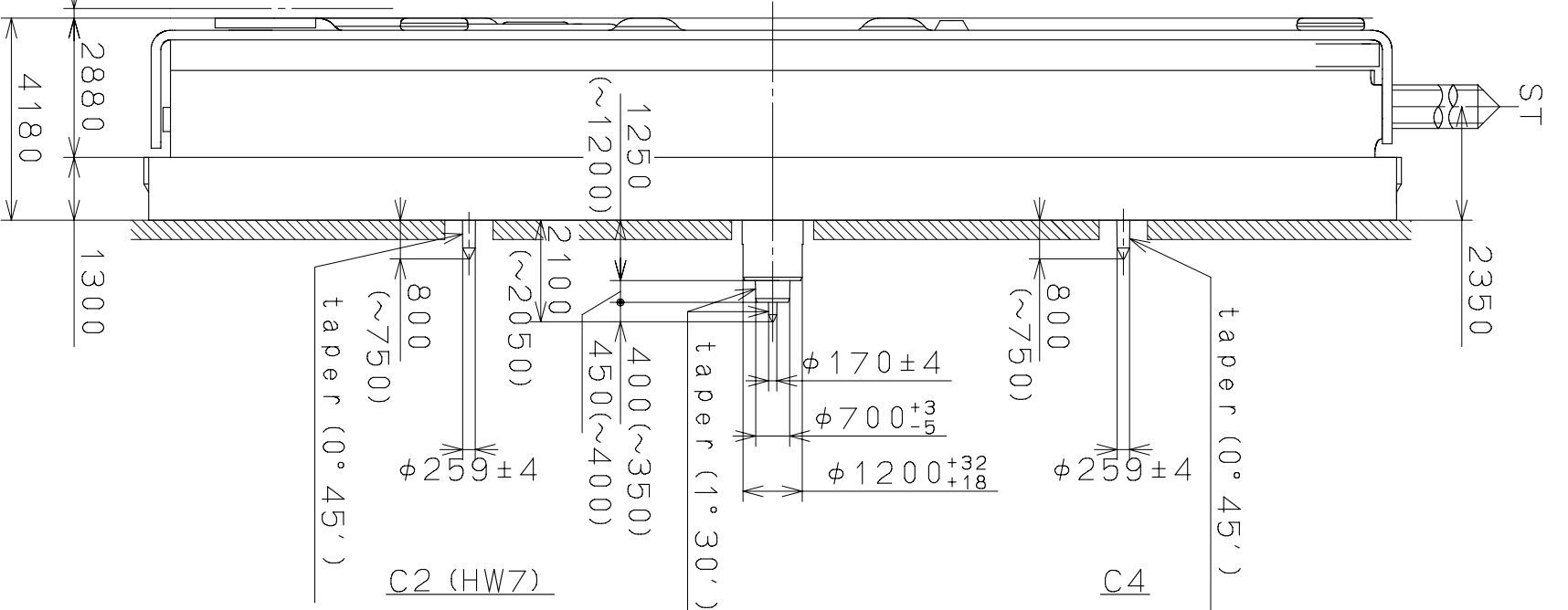
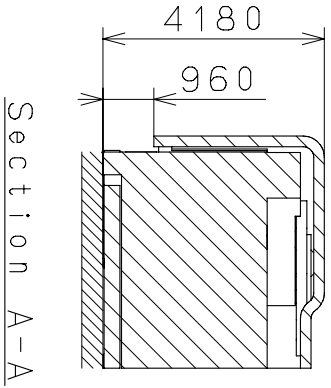

△5	Quantity		
△4	Unit	1/1000 mm	Cal. NO.: JR20
△3	Scale	7:1	Parts No.:
△2	Date		
△1	Drawn		
Mark	Date	Description	Approv. Checked
			N. Suzuki
Alterations	Approved	Name: F. Frame for Case	
Material	Drawing No.: JR20C000		
Heat Treatment	General Tolerances	<p>MIYOTA</p> <p>CITIZEN WATCH CO., LTD. TOKYO, JAPAN</p>	
Hardness	Dimensions		
Plating	Angles		

2008/02/04 (15:49:18)

This drawing is provisional and subject to our reconfirmation and/or revision without notice.

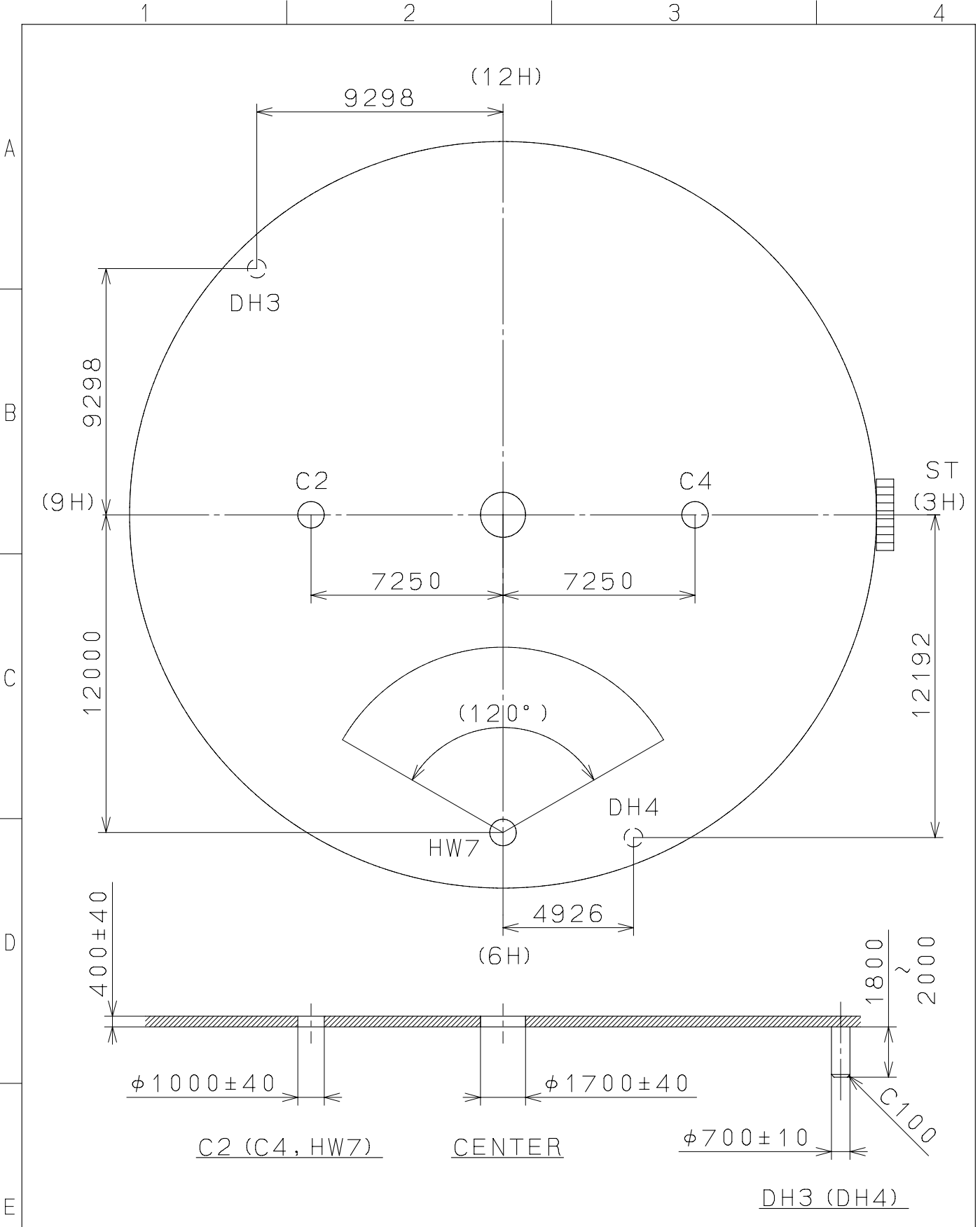

△			Quantity		Cal.NO.:
△			Unit	1/1000mm	JR20-00A
△			Scale	5:1	Parts No.:
△			Date		
△			Drawn		
Mark	Date	Description	Appr.	Checked	Name:
		Alterations	Approved	N. Suzuki	
Material					Indications for Dial
Heat Treatment					Drawing No.: JR20D000
Hardness					MIYOTA
Plating					

2006/12/25 (07:50:10)

This drawing is provisional and subject to our reconfirmation and/or revision without notice.

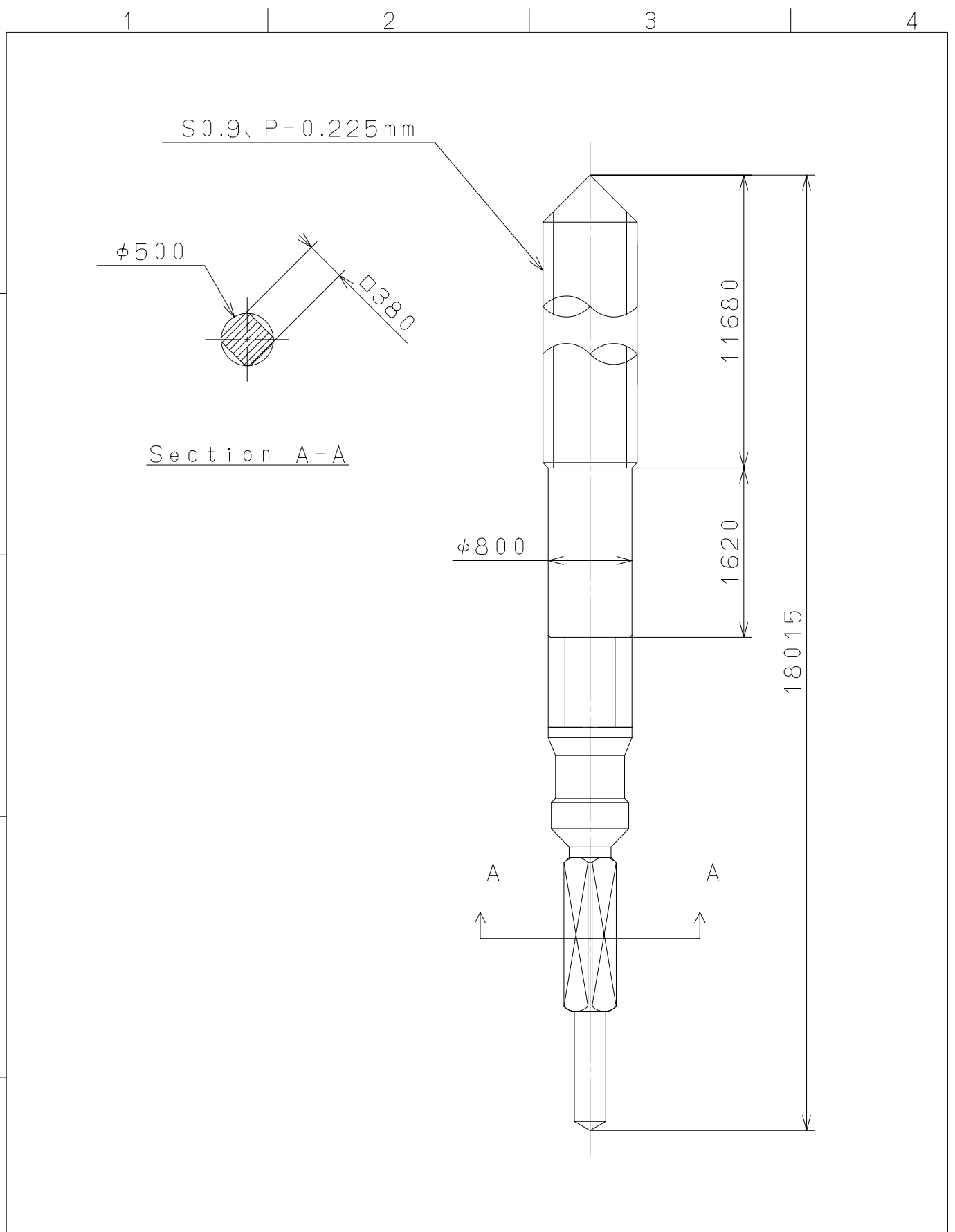

⑤			Quantity		Cal.NO.:
④			Unit	1 / 1000 mm	
③			Scale	20 / 1	Parts No.:
②			Date		065-505
①			Drawn		Name:
Mark	Date	Description	Appr.	Checked	T.Hiruta
Alterations			Approved	SETTING STEM	
Material				Drawing No.: 5050S000	
Heat Treatment				General Tolerances	
Hardness				Dimensions	
Plating				Angles	
				MIYOTA	
				CITIZEN WATCH CO., LTD. TOKYO, JAPAN	